



# User Guide

**NOKIA**  
LUMIA 2520

# Safety

Read these simple guidelines. Not following them may be dangerous or illegal.



## TURN OFF IN RESTRICTED AREAS

Turn the device off when mobile phone use is not allowed or when it may cause interference or danger, for example, in aircraft, in hospitals or near medical equipment, fuel, chemicals, or blasting areas. Obey all instructions in restricted areas.



## ROAD SAFETY COMES FIRST

Obey all local laws. Always keep your hands free to operate the vehicle while driving. Your first consideration while driving should be road safety.



## INTERFERENCE

All wireless devices may be susceptible to interference, which could affect performance.



## QUALIFIED SERVICE

Only qualified personnel may install or repair this product.



## BATTERIES, CHARGERS, AND OTHER ACCESSORIES

Use only batteries, chargers, and other accessories approved for use with this device. Do not connect incompatible products.



## KEEP YOUR DEVICE DRY

Your device is not water-resistant. Keep it dry.



## GLASS PARTS

The device screen is made of glass. This glass can break if the device is dropped on a hard surface or receives a substantial impact. If the glass breaks, do not touch the glass parts of the device or attempt to remove the broken glass from the device. Stop using the device until the glass is replaced by qualified service personnel.



## PROTECT YOUR HEARING

To prevent possible hearing damage, do not listen at high volume levels for long periods. Exercise caution when holding your device near your ear while the speakerphone is in use.



## SAR

This device meets RF exposure guidelines when used in the normal use position, in direct contact with the body. The specific maximum SAR values can be found in the Certification Information (SAR) section of this user guide. For more info, go to [www.sar-tick.com](http://www.sar-tick.com).

---

# Contents

Safety .....	1	People & messaging.....	27
Get started .....	4	<b>Contacts</b> .....	27
Keys and parts.....	5	<b>Social networks</b> .....	28
First start-up .....	6	<b>Mail</b> .....	29
Lock the screen .....	10	<b>Camera</b> .....	33
Antenna locations .....	11	<b>Take a photo</b> .....	33
Basics .....	12	<b>Record a video</b> .....	34
<b>Personalize your tablet</b> .....	18	<b>Photos hub</b> .....	34
<b>Take a screenshot</b> .....	20	<b>Maps &amp; navigation</b> .....	37
<b>Extend your battery life</b> .....	20	<b>Turn location services on</b> .....	37
<b>Save on data costs</b> .....	21	<b>HERE Maps</b> .....	37
<b>Text input</b> .....	22	<b>Positioning methods</b> .....	41
<b>Search your tablet</b> .....	24	<b>Internet</b> .....	42
<b>SkyDrive</b> .....	24	<b>Define how your tablet connects to the web</b> .....	42
<b>Nokia account</b> .....	26	<b>Web browser</b> .....	42
		<b>Close all network connections</b> .....	44

---

Entertainment.....	45	Troubleshooting and support.....	59
<b>Watch &amp; Listen .....</b>	<b>45</b>	Product and safety information..	60
<b>Get started with the Nokia Music app .....</b>	<b>46</b>	<b>Take care of your device .....</b>	<b>60</b>
<b>Windows Store.....</b>	<b>47</b>	<b>About Digital Rights Management .....</b>	<b>60</b>
<b>Games .....</b>	<b>49</b>	<b>Battery and charger info.....</b>	<b>61</b>
Office.....	50	<b>Additional safety information.....</b>	<b>61</b>
<b>Microsoft Office .....</b>	<b>50</b>	<b>Nokia Care .....</b>	<b>64</b>
<b>Calendar.....</b>	<b>52</b>	<b>Copyrights and other notices .....</b>	<b>64</b>
Device management & connectivity .....	53		
<b>Keep your tablet up to date .....</b>	<b>53</b>		
<b>Bluetooth .....</b>	<b>54</b>		
<b>NFC.....</b>	<b>55</b>		
<b>Memory and storage .....</b>	<b>56</b>		
<b>Security.....</b>	<b>57</b>		
<b>Access codes.....</b>	<b>58</b>		

# Get started



## Keys and parts



Some of the accessories mentioned in this user guide may be sold separately.

## First start-up

Learn how to get your new tablet up and running.

### Step 1: Charge the Tablet

Before turning on your tablet, charge it fully. Be sure to use the charger that came with your tablet.

Plug the charger into a wall outlet. Then connect it to your tablet. A green light on the charger will show your tablet is charging.



### Step 2. Turning Your Tablet On/Off

To turn your tablet on, press the Power/Lock Key.

To turn your tablet off, tap **Settings** > **Power** > **Shut down**.

## Optional: Remove the SIM Card

Your tablet came with the SIM card already installed. If you need to replace the SIM card:

1. Turn off the tablet.
2. Use the SIM door key to unlock the SIM/microSD card tray. Push the key into the hole until the tray is released.

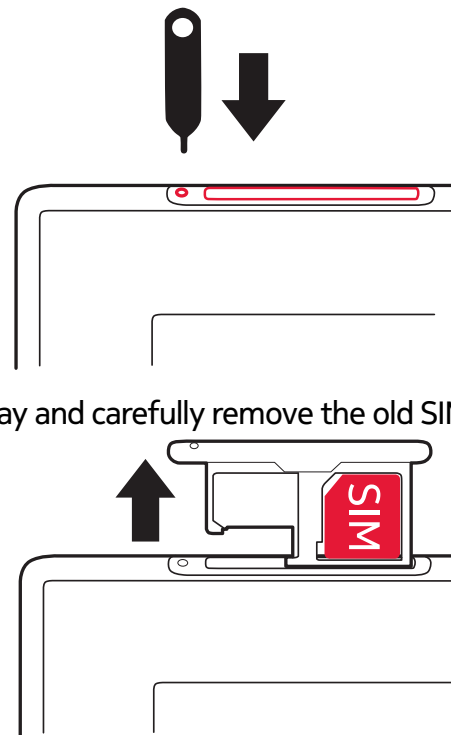

3. Pull out the tray and carefully remove the old SIM card.

4. Place the new SIM card in the tray, underneath the notch on the right side, with the contact area face down, and slide the tray back into the tablet.

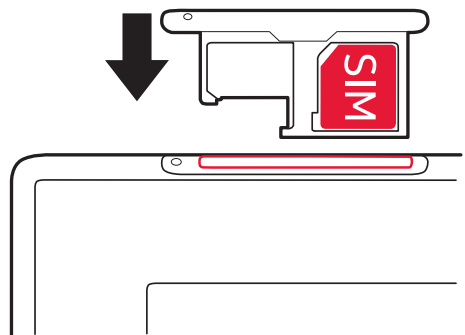

Your tablet uses a micro-SIM card, also known as a mini-UICC card.

 **Important:**

This device is designed to be used with a mini-UICC SIM card, also known as a micro-SIM card only. A micro-SIM card is smaller than the standard SIM card. Use of incompatible SIM cards, or use of SIM card adapters, may damage the card or the device, and may corrupt data stored on the card.

### Installing a microSD card

1. Turn off the tablet.
2. Use the SIM door key to unlock the SIM/microSD card tray. Push the key into the hole until the tray is released.

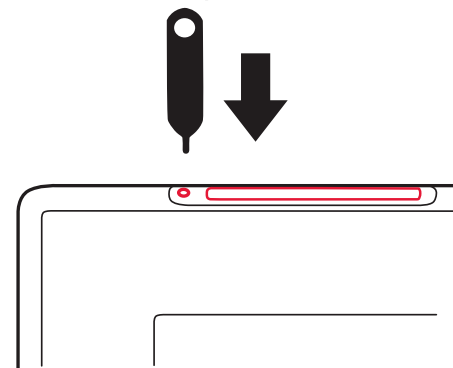

3. Pull out the tray.

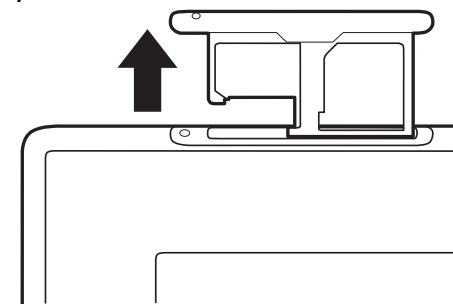

4. Place the card in the tray on the left side, with the contact area face down, and slide the tray back into the tablet.

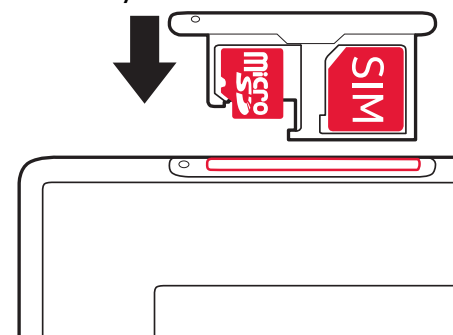



 **Note**

---

**Memory Card sold separately.**

---

Use only compatible memory cards approved for use with this device. Incompatible cards may damage the card and the device and corrupt data stored on the card.



Some microSD cards may not be compatible with this tablet.

Your tablet supports memory cards with capacity of up to 32 GB.

The tablet must be turned off before inserting the SIM or memory card.

Do not remove the memory card when the tablet is on. Doing so may damage the memory card and the tablet.

**Non-Removable Battery**

Your device is equipped with an internal rechargeable battery which should be replaced only by Nokia or an authorized Nokia repair center. You should never attempt to open or disassemble this device yourself and doing so may cause damage that voids your warranty.

 **Important:**

---

Only qualified personnel or an authorized service facility should replace the battery. Unauthorized battery replacement may invalidate your warranty.

---

**Set up your tablet**

Make your tablet your own right from the start.

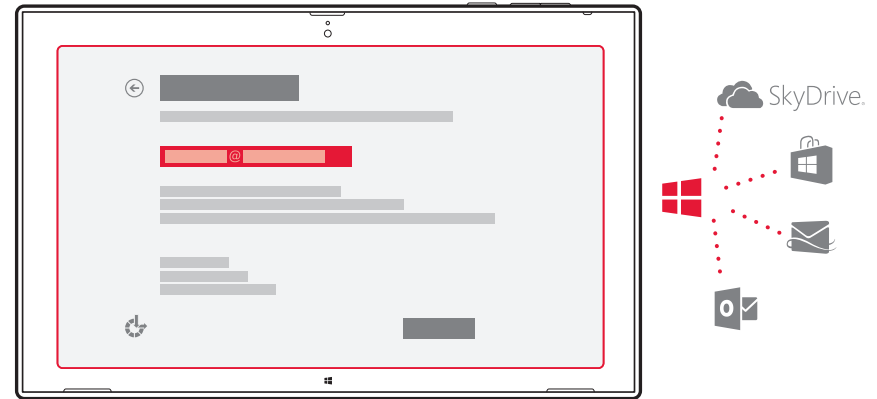

1. Turn your tablet on.
2. To set up and name your tablet, follow the instructions shown on the screen.
3. Create your Microsoft account, or sign in with your existing username and password. With a Microsoft account, you can, for example, get apps from Store or access more Microsoft services, such as SkyDrive.

 **Note:**

---

You need an Internet connection. If you don't have a data plan, data transmission costs may pile up quickly. For info about possible data costs, contact your network service provider.

---

4. If you can't connect to the Internet, you can create the account later.



**Tip:**

---

Forgot your password? You can request it to be sent to you in a mail or text message.

---

5. Finally, create a username and, if you want, also a password for your local user profile on your tablet.



**Tip:**

---

You can create several Microsoft accounts, for different family members, for example. When creating an account, tap **Add a child's account** to create an account for your child, with added features such as Family Safety and reports about your child's PC activities.

To change users, tap the username in the top right corner of the screen. Here you can also change the account picture, lock the tablet, or sign out.

---



**Example:**

---

To create a Microsoft account later, swipe in from the right of the screen, and tap **Settings > Change PC settings > Accounts > Other accounts > + Add an account**. To create your account on the Internet, go to [www.live.com](http://www.live.com).

---

## Connect the headset to your tablet

Enjoy your favorite music without background disturbance.

Connect the headset to your tablet.

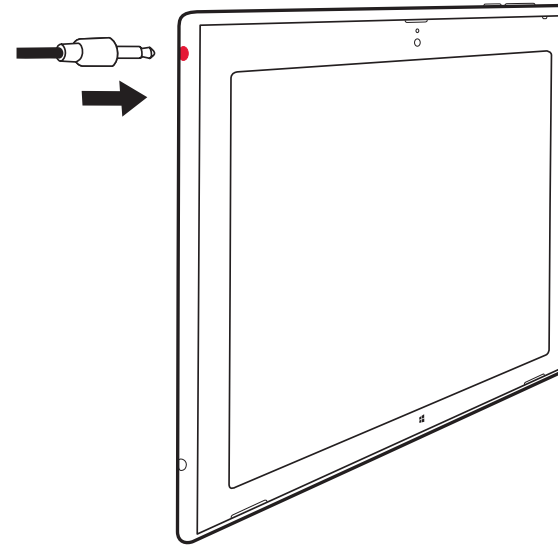

Do not connect products that create an output signal, as this may damage the device. Do not connect any voltage source to the headset connector. If you connect an external device or headset, other than those approved for use with this device, to the headset connector, pay special attention to volume levels.

## Change the volume

Trouble hearing music, or is the volume too loud? You can change the volume to your liking.

Press the volume keys up or down.

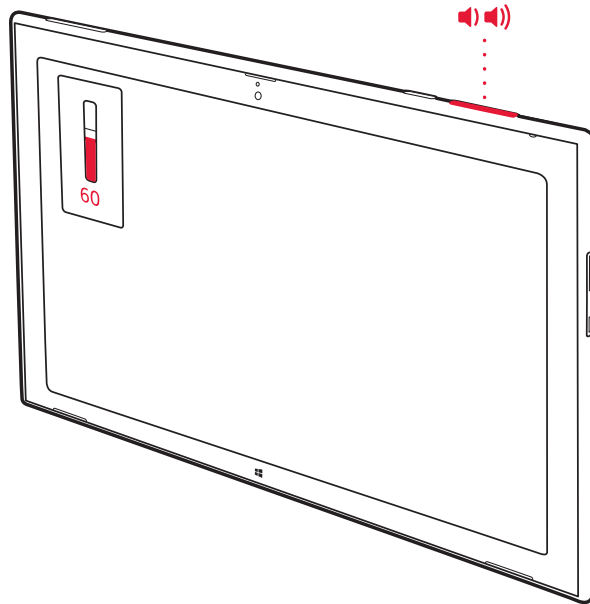

The volume keys control all sounds, including the volume of alarms and reminders.

## Lock the screen

Want to avoid accidental key presses when not using the tablet?

1. Quickly press the Power/Lock Key to turn on your screen. Your lock screen will appear.

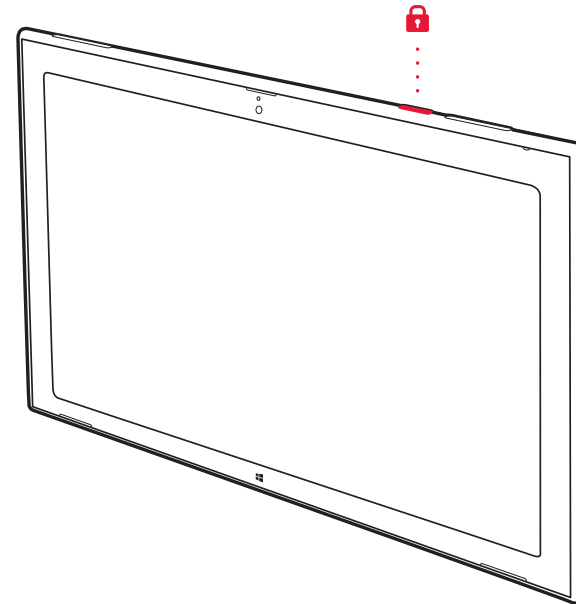

2. Swipe the screen up to unlock it.  
You can use the volume keys even when the screen is locked.

## Unlock the screen

Press the Power/Lock key, and drag the lock screen up.

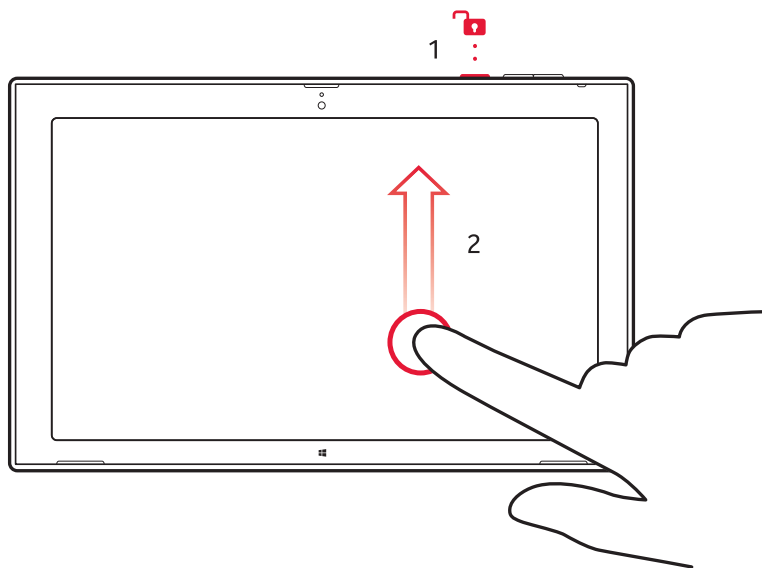

## Lock the screen rotation

Swipe in from the right of the screen, and tap **Settings** > **Screen** > .

## Unlock the screen rotation

Swipe in from the right of the screen, and tap **Settings** > **Screen** > .

## Antenna locations

Learn where the antennas are located on your tablet to get the best possible performance.

The antenna areas are highlighted.

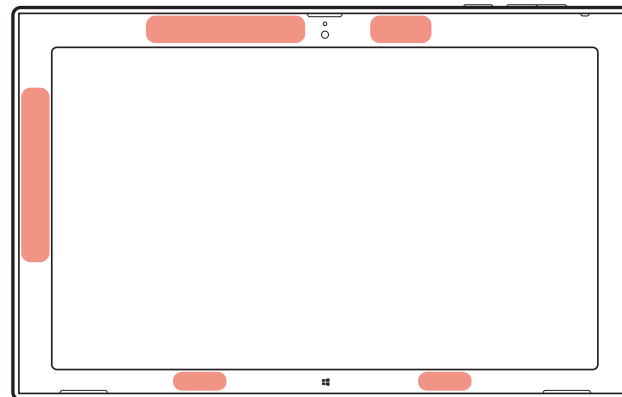

# Basics

Learn how to get the most out of your new tablet.

## Get to know your tablet

With your tablet, you can easily keep up with what's going on and always have your favorite stuff conveniently pinned to the Start screen.

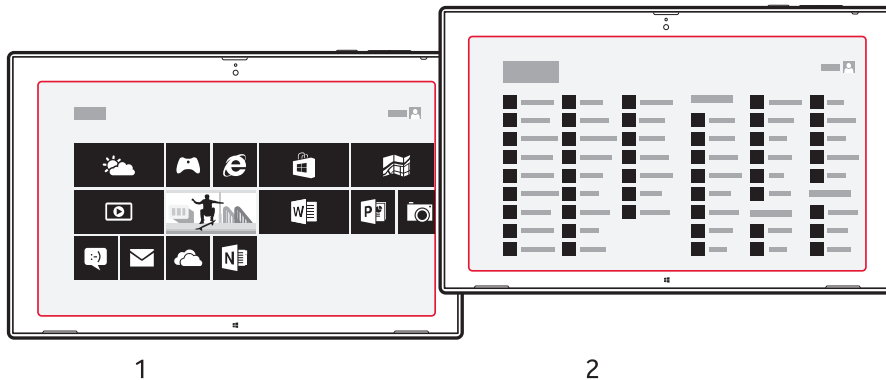

Arrange your most frequently used apps on the Start screen (1). You can find all your installed apps in the Apps menu (2).



**Tip:**

To switch from the Start screen to the Apps menu, swipe up.

## Touch Navigation

Use touch gestures to move around the screen, open menus, select items, zoom in or out of web pages or pictures, and more.

<b>Swipe</b>	Swipe by quickly sliding your finger in any direction. Try it: From your Start screen, swipe in from the left edge to switch to the previously used app or swipe in from the top or bottom edge to reveal commands specific to the current app.
<b>Drag</b>	Drag by touching an item and sliding it to a new position. Try it: Drag from the top edge of the screen down to the bottom to close the current app.
<b>Pinch to zoom</b>	Pinch or stretch your fingers to zoom in or out of a web page or picture.
<b>Rotate an item</b>	Place two or more fingers on the item, and rotate it.

From the Start screen, swipe in from the right edge to reveal CHARMS. You can also return to the Start screen from there.

## Use the touch screen

Explore your tablet with a tap, swipe, or drag.

1. To use your tablet, simply tap the touch screen.
2. To see detailed info or, while in Desktop, to see further options, tap and hold the item or app you want to explore.

### Example:

---

To open a menu with more options in Desktop, tap and hold the item.

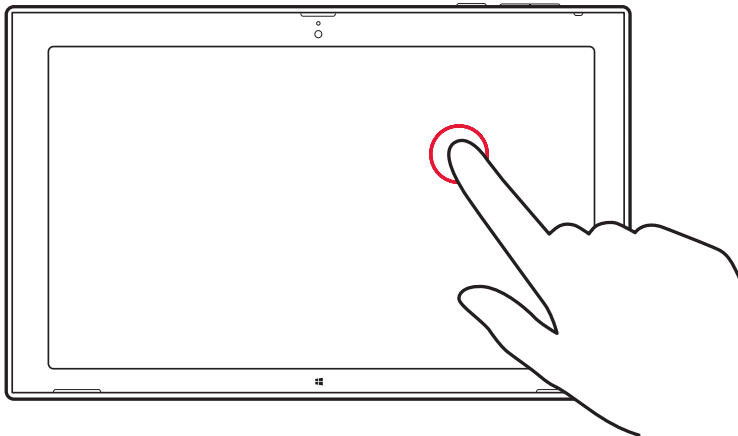

## Swipe

Place your finger on the screen, and slide it in the desired direction.

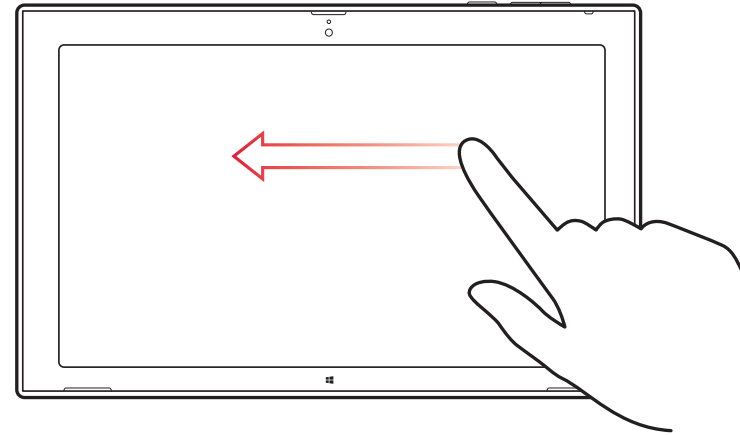

### Example:

---

To quickly scroll through a long list or menu, slide your finger quickly in a flicking motion up or down the screen, and lift your finger. To stop the scrolling, tap the screen.

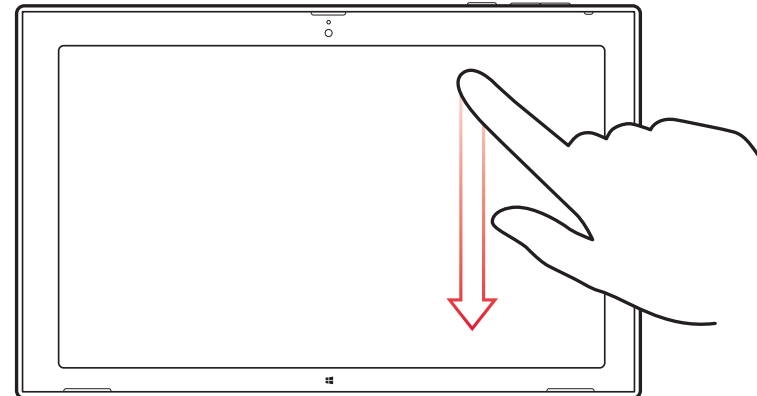

## Drag an item

From the Start screen, tap and hold an item, and slide your finger across the screen.



## Zoom in or out

Place 2 fingers on an item, such as a map, photo, or web page, and slide your fingers apart or together.

You may not be able to zoom in or out in all apps.

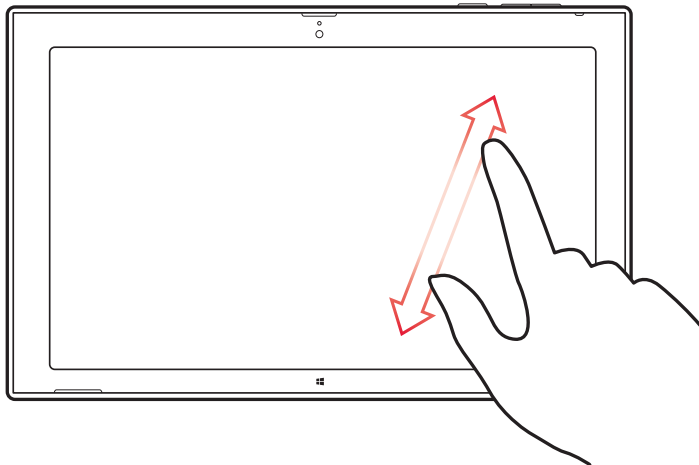

## Rotate an item

Place 2 or more fingers on the item, and rotate it.

You may not be able to rotate all items.

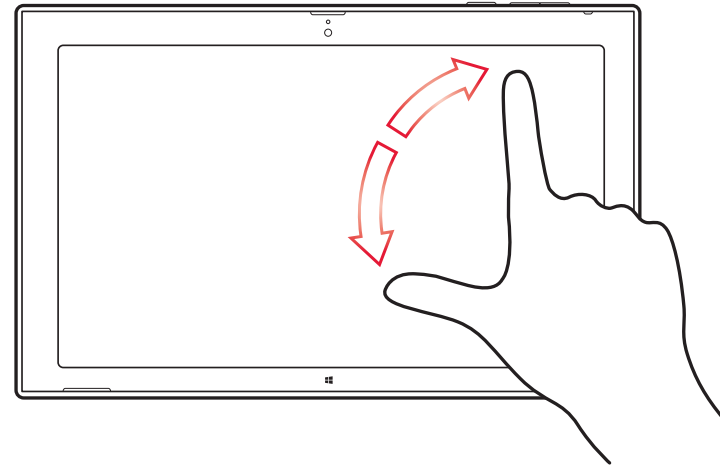

### Tip:

---

You can also rotate the whole screen. Simply turn the tablet 90 degrees.

---

### Important:

---

Avoid scratching the touch screen. Never use an actual pen, pencil, or other sharp object on the touch screen.





---

## Search, Share, Change Settings and More

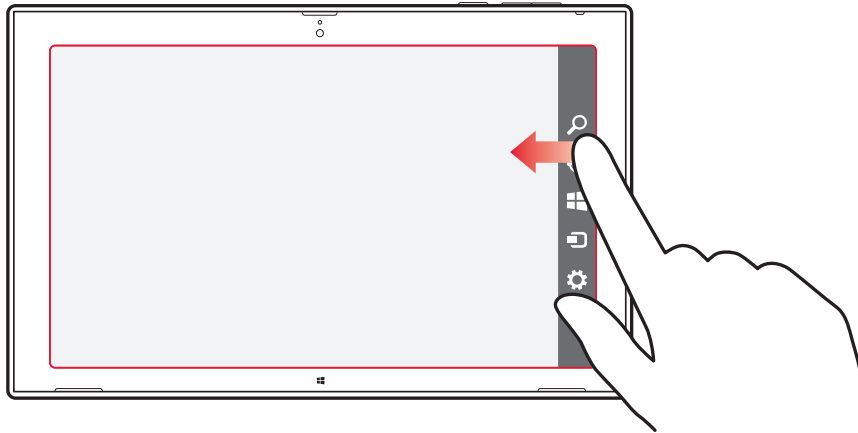
No matter where you are in Windows 8, the CHARMS help you do the things you do most often, like search, share links and photos, connect devices, and change settings.

What you can do with the CHARMS can change depending on whether you're on the Start screen or using an app, so start exploring.



 <b>Search</b>	Search for anything. You can search just the app you're in (like finding a specific message in Mail), search another app (look up something on the Internet), or you can search your entire PC (for an app, setting, or file).
 <b>Share</b>	Share files and info with people you know or send info to another app, without leaving the app you're in. You can email photos, update your Facebook status, or send a link to your note-taking app.
 <b>Start</b>	Get to your Start screen. Or if you're already there, you can use this charm to go back to the last app you were in.
 <b>Devices</b>	Use devices that are connected to your PC, both wired and wireless. You can print from an app, sync with your phone, or stream your latest home movie to your TV (with compatible devices).

 **Settings** Change settings for apps and your PC. You'll find settings, help, and info for the app you're in, plus common PC settings — network connection, volume, brightness, notifications, power, and keyboard. These PC settings are the same no matter where you are in Windows, but the app settings are different in every app. You can also change settings for your PC when you select Change PC settings. It's where you change your lock screen picture, manage notifications, and more.

## See more options

In any app or on the Start screen, swipe up from the bottom of the screen for more options, such as adding attachments in Mail.

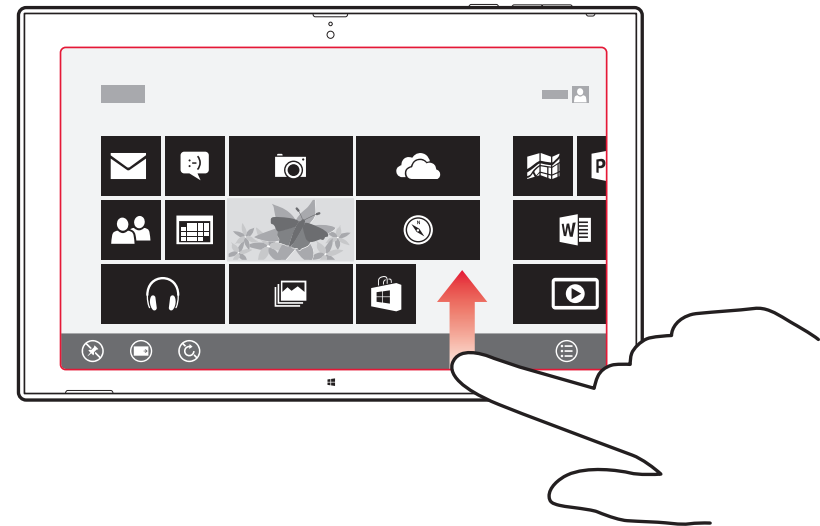



## Switch between apps

When you've got lots of different things to do, it's easy to switch between the tasks at hand.

1. Swipe in from the left side of the screen to see your most recently used apps.

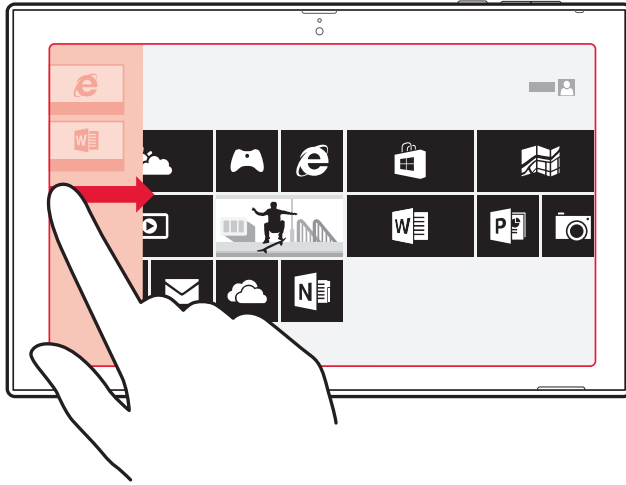

2. To switch to an app, simply tap the app.

## Close an app

Slide your finger down from the top of the screen all the way to the bottom of the screen.

## Split the screen

Ever feel like doing 2 things at the same time? Split the screen to multitask efficiently.

1. Slide your finger in from the left side of the screen to grab a currently running app.
2. Drag and drop the app to the left or right half of the screen. The screen will be split with a divider. The app opens on the side where you dropped it.

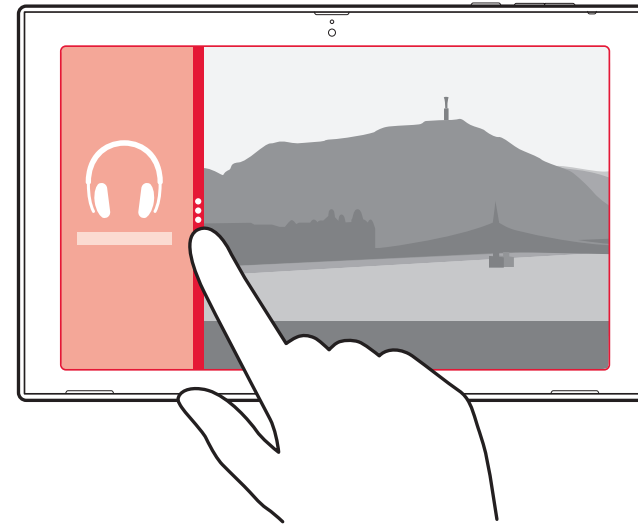

 **Tip:**

---

To resize the app views, drag the screen divider left or right.

---

## Use your tablet with ease

You can make your tablet tell you what is shown on the screen, and make the screen easier to view.

Swipe in from the right of the screen, and tap **Settings > Change PC settings > Ease of Access**.

## Use the screen reader

Tap **Narrator**, and turn **Narrator On** .

To hear the names of the items on the screen, move your finger on the screen. To open an item, double-tap the item.

To turn the screen reader off, press  and the volume up key at the same time.

## Turn high contrast on



Tap **High contrast**, and choose the theme you want.

## Make notifications show for longer

Tap **Other options**, and change the setting for **Show notifications for**.

## Magnify the screen

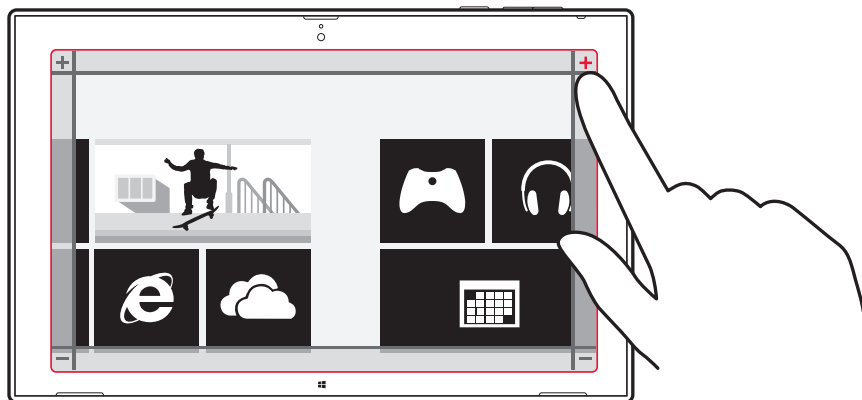

Are the icons and text on your tablet too small? Magnify the screen, so you can read more easily.

1. Tap **Magnifier**.
2. Turn **Magnifier On** .
3. To zoom in, tap .



4. To move on the magnified screen, swipe left, right, up, or down on the frame around the screen.



## Turn the magnifier off

Tap  until the icon is no longer shown, and tap .

## Use your tablet in airplane mode

In places where you're not allowed to connect to the Internet with your tablet, you can still access your music, videos, and offline games if you turn airplane mode on.

Airplane mode closes connections to the mobile network and turn your phone's wireless features off. Comply with the instructions and safety requirements given by, for example, your airline, and any applicable laws and regulations. Where allowed, you can connect to a Wi-Fi network to, for example, browse the Internet or turn Bluetooth and NFC sharing on in airplane mode.

1. Swipe in from the right of the screen, and tap  **Settings** > **Change PC settings** > **Network** > **Airplane mode**.
2. Turn **Airplane mode On** .

## Personalize your tablet

Learn how to rearrange the Start screen to suit your needs, and how to change themes and tones to suit your mood.

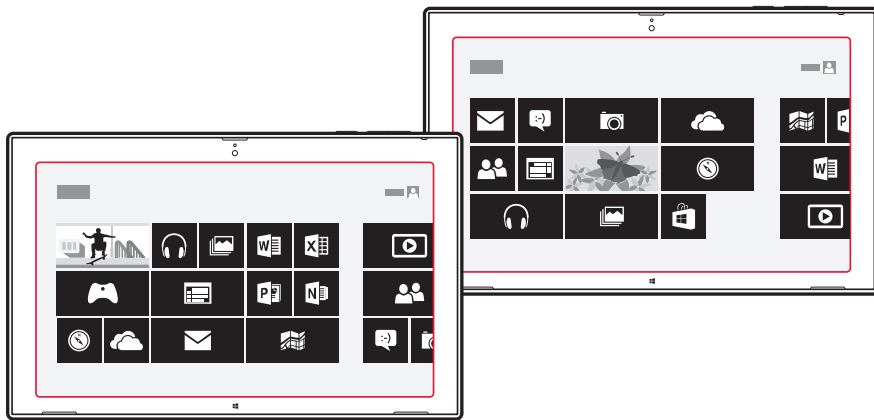

## Personalize the Start screen

Always have your apps but a tap away. You can pin apps, contacts, and websites to the Start screen, and group tiles as you like. Some tiles can be resized, or turned live to show, for example, the latest news.

1. Tap and hold the tile you want to move.
2. Drag and drop the tile to a new location.



### Tip:

To quickly move a tile from one side of the screen to the other, drag the tile to the bottom of the screen, and hold it still for a couple of seconds. The Start screen zooms out, and you can easily move the tile to a new location anywhere on the screen.

## Pin an app

Tap and hold the app, and tap  **Pin to Start**.



### Tip:

Changed your mind? To clear the selection, tap the app again.

## Unpin a tile

From the Start screen, tap and hold a tile, and tap  **Unpin from Start**.

Unpinning a tile removes it from the Start screen, but it doesn't, for example, uninstall the app or remove the website from your favorites.

## Change tile settings

From the Start screen, tap and hold the tile to show the tile options.

### Tip:

You can, for example, resize some tiles, or turn a live tile on or off. The live tiles update when your tablet is connected to the Internet.

## Modify your theme

You can modify your tablet's display theme, to match your taste and mood.

1. Swipe in from the right of the screen, and tap  **Settings** > **Personalization**.
2. Modify your theme.

## Personalize your tones

You can select the best sounds for your tablet.

1. Swipe up to the Apps menu and tap **Desktop**.
2. Swipe in from the right of the screen, and tap  **Settings** > **Personalization** > **Sounds**.
3. From the list shown, tap the type of tone or alert you want to change, and tap **Browse** to select a sound. To listen to a sound, tap **Test**.

### Tip:

You can create sound schemes for different situations, for example, more discreet sounds to use when you're at the office. After you've changed the sounds to your liking, tap **Save As...** to save the sounds as a scheme.

## Take a screenshot

Save the things on your screen by taking a screenshot.

Press the volume down key and the start key  at the same time.

To view the screenshot you've taken, tap  **Photos > Screenshots**.

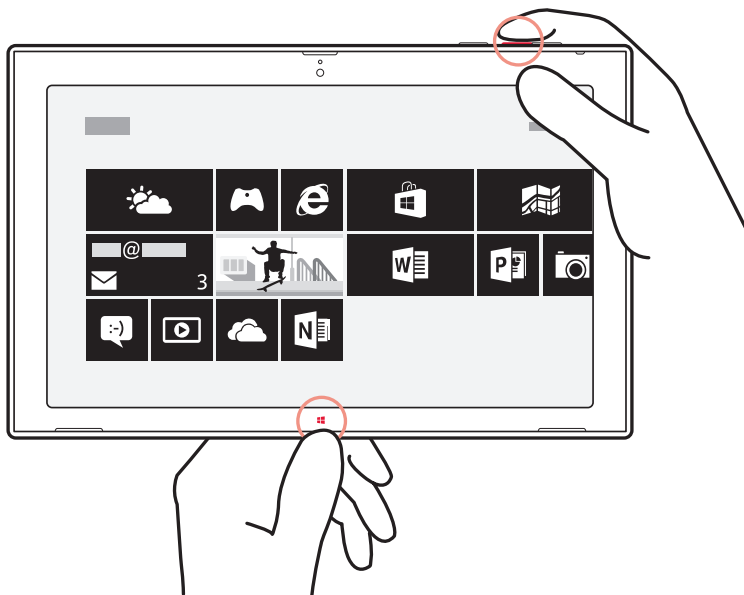



## Extend your battery life









Find the balance between getting the most out of your tablet while getting the battery life you need.

There are steps you can take to save power on your tablet.

To save power:

Charge wisely	Always charge the battery fully.
Select only the sounds that you need	Mute unnecessary sounds, such as key press sounds.
Use wired headphones	Use wired headphones, rather than the loudspeaker.
Set the tablet screen to turn off after a short time	Swipe in from the right of the screen, and tap  <b>Settings &gt; Change PC settings &gt; PC and devices &gt; Power and sleep</b> , and under <b>Sleep</b> , select the length of time you want.
Set the tablet to adjust the screen brightness manually	Swipe in from the right of the screen, and tap  <b>Settings &gt; Change PC settings &gt; PC and devices &gt; Power and sleep</b> . Turn <b>Adjust my screen brightness automatically Off</b>  .
Lower the screen brightness	In the Apps menu, tap <b>Control Panel &gt; Hardware and Sound</b> . Under <b>Power Options</b> , tap <b>Adjust screen brightness &gt; Change plan settings</b> , and select the level you want. To save the changes, tap <b>Save changes</b> .

Use network connections selectively

- Set your tablet to check for new mail less frequently. Tap  **Mail**, swipe in from the right of the screen, and tap  **Settings** > **Accounts**. For each account, tap the account name, and change the setting for **Download new email**.
- Turn Bluetooth on only when needed.
- Turn NFC on only when needed. To turn NFC off, swipe in from the right of the screen, tap  **Settings** > **Change PC settings** > **Network** > **Airplane mode**, and turn **NFC Off** .
- Use Wi-Fi to connect to the Internet, rather than a mobile data connection.
- Stop your tablet scanning for available wireless networks. Swipe in from the right of the screen, and tap  **Settings** > **Change PC settings** > **Network** > **Airplane mode**. Then turn **Wi-Fi Off** .
- If you're listening to music or otherwise using your tablet, but don't want to connect to the network, swipe in from the right of the screen, tap  **Settings** > **Change PC settings** > **Network** > **Airplane mode**, and turn **Airplane mode On** .

## Save on data costs

Want to go easy on your operator bills? Here's how you can save on data roaming costs.

Data roaming means using your tablet to receive data over networks that your network service provider doesn't own or operate. Your network service provider can charge you a fixed fee for data transfer or on a pay as you use basis.

To save on data roaming costs:

- Connect your tablet to a Wi-Fi network. Using a Wi-Fi connection is generally faster and less expensive than using a mobile broadband connection. If both Wi-Fi and mobile broadband connections are available, your tablet uses the Wi-Fi connection.
- Close the mobile broadband connection
- Change mail download settings
- Change sync settings

## Connect to a Wi-Fi network

Connecting to a Wi-Fi network is a handy way of accessing the Internet. When out and about, you can connect to Wi-Fi networks in public places, such as a library or Internet café.

Swipe in from the right of the screen, and tap  **Settings** > .

1. Turn **Wi-Fi On** .
2. Select the connection you want to use.

## Close the connection

Turn **Wi-Fi Off** .

## Close the mobile broadband connection

Close your mobile broadband connection while, for example, traveling abroad, and you can save on data costs.

1. Swipe in from the right of the screen, and tap **Settings** > **Network**.
2. Turn **Mobile broadband Off**.

## Set mail download to manual

To help save on data costs, set your tablet to check for new mail by request only.

1. Swipe up, and tap **Mail**.
2. Swipe in from the right of the screen, and tap **Settings** > **Accounts**.
3. For each account, tap the account name, and turn **Download new email** to **manual**.

## Prevent downloading over metered connections

To avoid extra charges, you can prevent your tablet from downloading device software, such as drivers and apps, while using metered Internet connections. If your network service provider charges by the amount of data you send and receive, you have a metered connection.

1. Swipe in from the right of the screen, and tap **Settings** > **Change PC settings** > **PC and devices** > **Devices**.
2. Turn **Download over metered connections Off**.

## Text input

Learn how to write text quickly and efficiently with your tablet's keyboard.

### Use the on-screen keyboard

Writing with the on-screen keyboard is easy and fun. You can use the keyboard when holding your tablet in portrait or landscape mode.

Tap a text box.

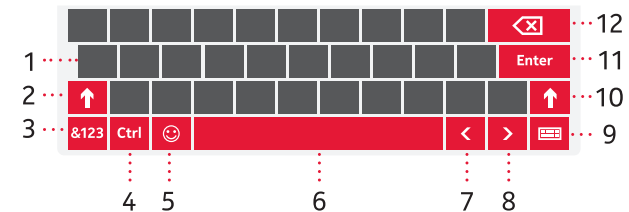

1. Character keys
2. Shift key
3. Numbers and symbols key
4. Control key
5. Emoticon key
6. Space key
7. Left arrow key
8. Right arrow key
9. Writing language key
10. Shift key
11. Enter key
12. Backspace key

The keyboard layout can vary in different apps and languages. The example shows the English keyboard.

### Switch between upper and lower case characters

Tap the shift key. To turn caps lock on, double-tap the key. To return to normal mode, tap the shift key again.

## Type in a number or special character

Tap the numbers and symbols key. To see more special character keys, tap ☺. Some special character keys bring up more symbols. To see more symbols, tap and hold a symbol or special character.

### Tip:

To put a full stop at the end of a sentence, and to start a new sentence, double-tap the space key.

## Add an accent to a character

Tap and hold the character, and tap the accented character.

## Delete a character

Tap the backspace key.

## Add an emoticon

Tap the text box and 😊.

## Switch between the writing languages

Tap the writing language key. This will change the keyboard layout as well as the word suggestions to the language you choose.

## Hide the keyboard

Swipe in from the right of the screen. To open the keyboard again, swipe right all the way off the screen.

## Add writing languages

You can add several writing languages to your keyboard and switch between the languages when writing.

1. Swipe in from the right of the screen, and tap **Settings** > **Change PC settings** > **Time and language** > **Region and language**.
2. Under **Languages**, tap **Add a language**.
3. Select the languages you want to write in.

## Switch between the languages when writing

Tap the writing language key.

The keyboard layout and word suggestions change according to the language selected.

## Use keyboard word suggestions

Your tablet suggests words as you write, to help you write quickly and more accurately. Word suggestions are available in several languages.

When you start writing a word, your tablet suggests possible words. When the word you want is shown in the suggestion box, tap the word.

## Correct a word

If you notice that you've misspelled a word, tap and hold it to see suggestions for correcting the word.

## Add a new word to the dictionary

If the word you want isn't in the dictionary, write the word, then tap and hold it, and tap **Add to dictionary** in the suggestion box.

## Turn word suggestions off

Swipe in from the right of the screen, and tap **Settings** > **Change PC settings** > **PC and devices** > **Typing**. Under **Typing**, turn **Show text suggestions as I type Off**.



## Search your tablet

Explore your tablet with Bing search. Find what you're looking for in the files, folders, and apps on your tablet, or search the web for info.

1. Swipe in from the right of the screen, and tap **Search**.
2. Write your search word in the search box and tap **Search**.

You can also select from the proposed matches.

## SkyDrive

Store your stuff in the clouds. You don't need to worry about freeing memory for your favorites or new apps, as you can store your stuff in the cloud, and download them when you need them.

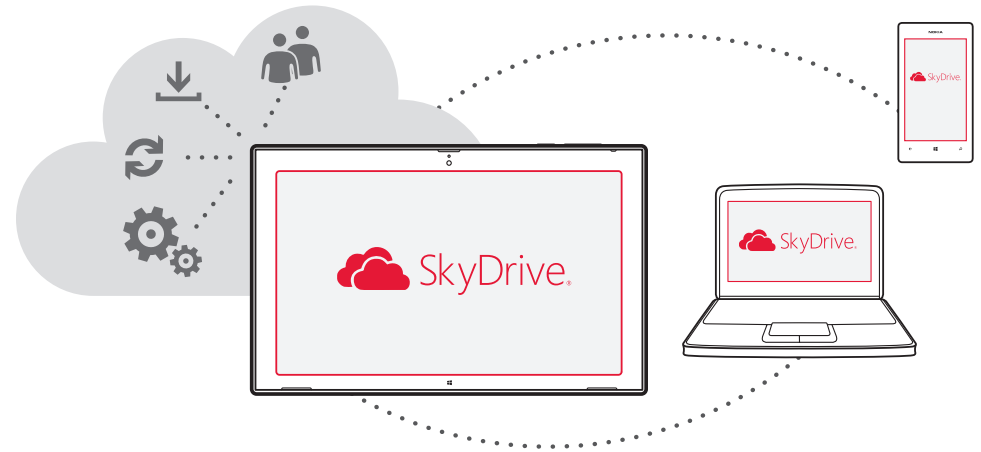

With SkyDrive, you can access your photos, documents, and more from your phone, tablet, or computer. Depending on the app, you can even continue working on a document right from where you left it earlier.



## Save your photos and other stuff to SkyDrive

You can upload files saved on your tablet to SkyDrive for easy access from your phone, tablet, or computer.

You need a Microsoft account and Internet connection to connect to SkyDrive.

1. Tap  **SkyDrive**.
2. Swipe up from the bottom of the screen, and tap  **Add files**.
3. Select the files you want to upload. You can select files from several folders or apps. The files to be uploaded are listed at the bottom of the screen. To remove a file from the list, tap the file.
4. To start the upload, tap **Copy to SkyDrive**.

The files are uploaded straight to the SkyDrive main view, but you can manage them later online.

## Manage your files in SkyDrive

You can create new folders to your SkyDrive, open files straight from SkyDrive, or delete stuff you no longer need.

You need a Microsoft account and Internet connection to connect to SkyDrive.

Tap  **SkyDrive**.

### Create a new folder

Swipe up from the bottom of the screen, tap  **New folder**, type the folder name, and tap **Create**.

### Open a file

Tap and drag down the file you want to open, and tap  **Open with** and the app you want to use.

### Delete files or folders

Tap and drag down the files and folders you want to delete, and tap  **Delete**.

## Share your photos, documents and other stuff between your devices

With SkyDrive, you can easily access your photos, documents, and other stuff you have uploaded from any of your devices.

To upload your photos, documents, or other stuff saved on your phone, tablet, or computer to SkyDrive, you need to sign in to your Microsoft account. To access the uploaded content on another device, you need to sign in to the same Microsoft account that was used when uploading the content.

To upload or download content, you need an Internet connection. If you don't have a data plan, the data transmission costs may pile up quickly. For info about possible data costs, contact your network service provider.

On your tablet or computer, you can either manage your stuff online at [www.skydrive.com](http://www.skydrive.com), or you can use the SkyDrive app and access SkyDrive straight from your desktop.

 **Tip:**

---

With the SkyDrive app on your computer, you can simply drag and drop the files you want to upload to the SkyDrive folder in the file manager, such as Windows Explorer, and the files are automatically uploaded to SkyDrive.

---

## **Nokia account**

Your Nokia account is the key to Nokia services.

To create your Nokia account, open the My Nokia app. The tutorial guides you through account creation.

With your Nokia account, you can, for example:

- Access Nokia services with a single username and password on your computer or tablet.
- Buy music from Nokia Music
- Sync your favorites in Maps
- Download content from Nokia services
- Save your contact info. You can also add your payment card details to your Nokia account.

The available services may vary.

To learn more about the Nokia account and Nokia services, go to **[account.nokia.com](http://account.nokia.com)**.

# People & messaging

Contact your friends and family, and share your files, such as photos, using your tablet. Stay tuned with the latest updates to your social networking services even when on the go.

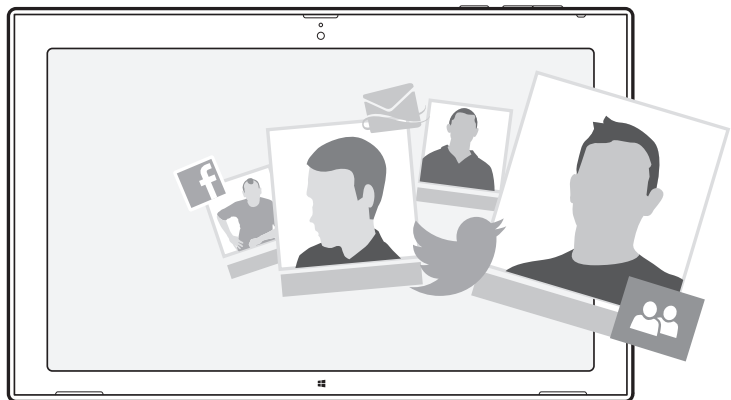

## Contacts

You can save and organize your friends' phone numbers, addresses, and other contact info in the People Hub. You can also get in touch with your friends through social networking services. You must be signed in to your Microsoft account to get to the People Hub.





## Add a new contact

Keep your friends with you. Save their phone numbers, addresses, and other info to the People Hub.

1. Tap  **People**.
2. Swipe up from the bottom of the screen, and tap  **New contact**.
3. In the **Account** text box, tap the account to which you want to add the contact.
4. Fill in the contact details, and tap .

## Edit a contact

1. In the People Hub, tap a contact.
2. Swipe up from the bottom of the screen, and tap  **Edit**.
3. If you've linked the contact info from several accounts, tap the account where you want to edit the contact.
4. Edit the info, and tap .

## Delete a contact

1. In the People Hub, tap a contact.
2. Swipe up from the bottom of the screen, and tap  **Delete**.
3. If you've linked the contact info from several accounts, select the accounts from which you want to delete the contact.
4. Tap **Delete**.

The contact is deleted both from your tablet and, with some exceptions such as Facebook, Twitter, and LinkedIn, from the online services where it's stored.

## Social networks

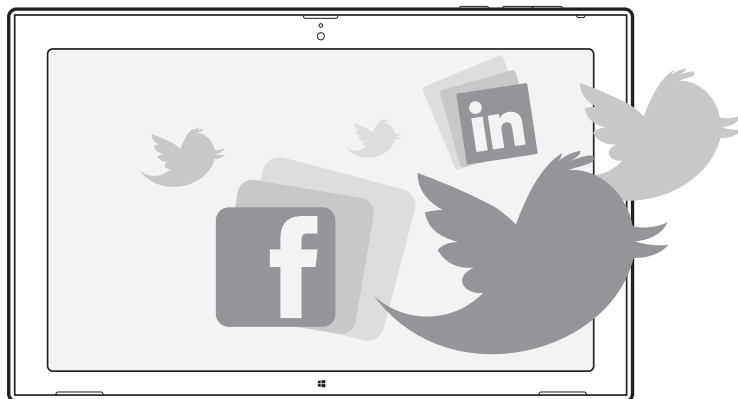

Want to keep in touch with your friends? Set up social networking services on your tablet.



Social networking services on your tablet keep you connected.

## Set up an account

Set up your social networking service accounts.

1. Tap  **People**.
2. Swipe in from the right of the screen, and tap  **Settings** > **Accounts**.
3. Tap **Add an account** and the name of the service, and follow the instructions shown.

 **Tip:**

---

When you sign in to an account, the contacts in the account are automatically imported to your People Hub.

---



## See your friends' status updates

After you set up your social networking services on your tablet, you can follow your friends' status updates in the People Hub.

Tap  **People** > **What's new**.

## Post your status

If you feel like reaching out to your friends, let them know what's on your mind. Post a status update to the social networking services that you use.

1. Tap  **People** and your own profile photo.
2. In the What's new view, select the service you want to post to from the drop-down list.
3. Write your message, and tap .

## Mail

You can use your tablet to send, read, and reply to mail when you are on the go.

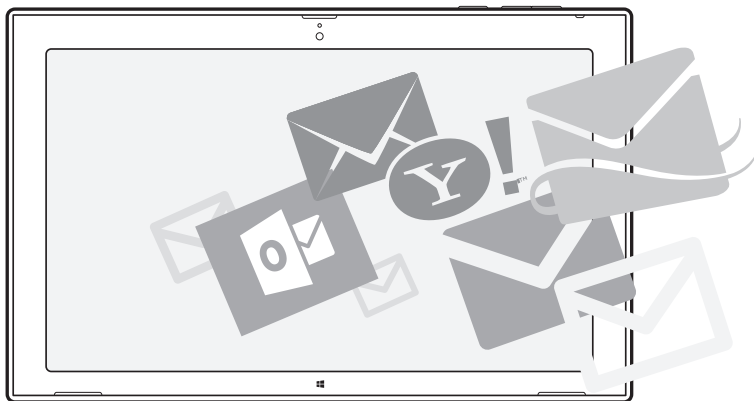

You can open Mail directly from the Start screen. Tap  **Mail**.

To send and receive mail, you must be connected to the Internet.



You must be signed in to your Microsoft account before you can use Mail. When you add a Microsoft account to your tablet, a mail account is added automatically.

### Add a mailbox

Do you use different mail addresses for business and leisure? You can add several mailboxes to your tablet.

If you haven't signed in to your Microsoft account while getting started with your tablet, you can sign in now. Tap  **Mail**, and follow the instructions shown on your tablet. Your mail account is also added automatically.

## Add other mail accounts

1. Tap  **Mail**.
2. Swipe in from the right of the screen, and tap  **Settings** > **Accounts**.
3. Tap **Add an account**.
4. Tap an account type, and write your address and password.

 **Tip:**

---

To use your work mail, contacts, and calendar with your tablet, add an Exchange ActiveSync account to your tablet. Tap **Exchange** > **Show more details**, and type in the required details.

---

5. Tap **Connect**.

 **Tip:**

---

Depending on your mail account, you can also sync other items to your tablet, such as contacts and your calendar.

---

If your tablet doesn't find your mail settings, you can use advanced setup. For this, you need to know your mail account type and the addresses of your incoming and outgoing mail servers. You can get this info from your mail service provider.

While selecting the account type, tap **Other Account**, select the account type, and tap **Connect**. Then tap **Show more details**, type in the required details, and tap **Connect**.

## Exchange ActiveSync

Would you like to have your work mail, contacts, and calendar at hand, whether you are sitting by your computer or on the go with your tablet? You can sync the important content between your tablet and a Microsoft Exchange server.

Exchange ActiveSync can be set up only if your company has a Microsoft Exchange server. In addition, your company IT administrator must have activated Microsoft Exchange ActiveSync for your account.

Before starting the setup, make sure you have the following:

- A corporate mail address
- Your Exchange server name (contact your company IT department)
- Your network domain name (contact your company IT department)
- Your office network password

Depending on the Exchange server configuration, you may need to type in additional info during the setup. If you don't know the correct info, contact your company IT department.

During the setup, you can define how often you want your tablet to sync the content with the server. Only content defined when setting up the account is synced. To sync additional content, change the Exchange ActiveSync account settings.

With Exchange ActiveSync, it may be mandatory to use a lock code.

## Open mail from the Start screen

With live mail tiles, you can open mail directly from the Start screen.

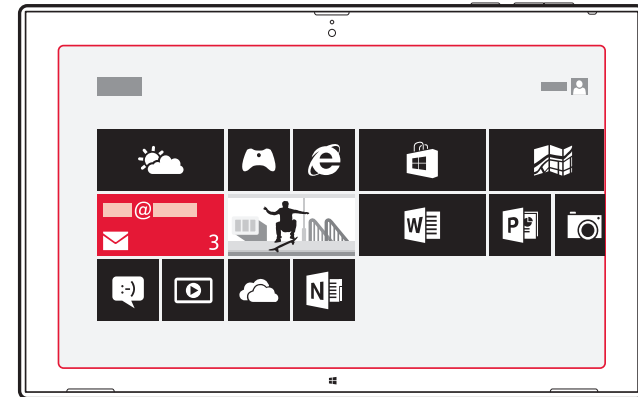



From the tile, you can see the number of unread mail and if you've received new mail. You can also see a short preview of the new mail. If you have several mailboxes, but only one tile for mail, you can see to which mailbox the mail has arrived.

You can pin several mailboxes to the Start screen. For example, dedicate a tile for business mail and another for personal mail. In your mailbox, swipe up from the bottom of the screen, and tap  **Manage folders > Pin to Start**.

To read your mail, tap the tile.

## Send mail

Don't let your mail pile up. Use your tablet to read and write mail on the go.

1. Tap  **Mail**.
2. If you have several mailboxes on your tablet, tap an account at the bottom left corner of the screen, and tap .
3. To add a recipient from your contact list, tap **To** and a contact, and tap **Add**. You can also write the address.
4. Write the subject and your mail.

 **Tip:**

---

To add a emoticon, tap .

---

5. To add an attachment, tap . Tap a file and **Attach**.

 **Tip:**

---

Swipe down over the keyboard to close it.

---

 **Tip:**

---

If the attachment is very large, you can send the message using SkyDrive attachments. Recipients can see previews of your attached files, launch a slide show to view photos, and open and edit documents. They only need to sign in to SkyDrive to download a large file.

---

6. To send the mail, tap .

## Read mail

Waiting for important news? Use your tablet to read your mail even when you're not sitting at your desk.

You can see when you have new mail on the Start screen.

Tap  **Mail**. The reading pane on the right shows the latest mail.

 **Tip:**

---

To zoom in or out, place 2 fingers on the screen, and slide them apart or together.

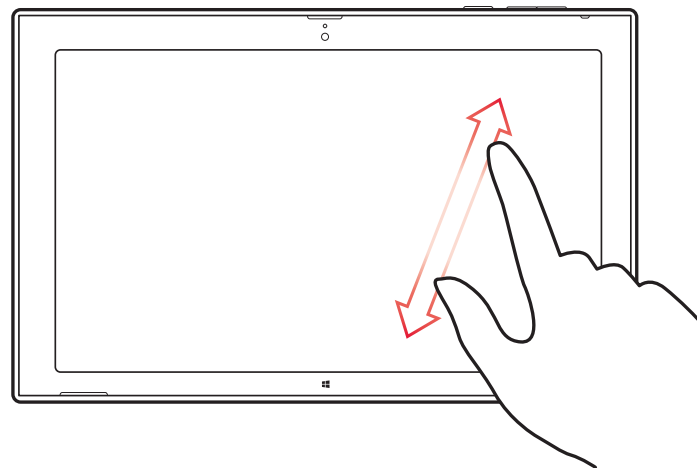

 **Tip:**

---

If a mail contains a web address, tap it to go to the website.

---

If you have several mailboxes on your tablet, you can read all your mail in one view. Tap a mailbox at the bottom left corner of the screen to switch between mailboxes.



## Read your mail later



In your inbox, tap the mail. Titles of unread mails are written in bold.

## Save an attachment

With the mail open, tap the attachment, such as a photo, to download it to your tablet. Tap the attachment and **Save**.

## Reply to mail

Do you receive mail that needs a quick answer? Reply straight away using your tablet.

1. Tap  **Mail**.
2. Tap the mail and . To reply to the sender only, tap **Reply**. To reply to the sender and all other recipients, tap **Reply all**.

## Forward mail

Tap the mail and  > **Forward**.



## Delete mail

Is your mailbox overflowing? Delete some mail to free up space on your tablet.

1. In your mailbox, tap the mail you want to delete.
2. Tap .

## Delete a mailbox

If you don't want to use a mailbox anymore, you can delete it from your tablet.

1. Tap  **Mail**.
2. Swipe in from the right of the screen, and tap  **Settings** > **Accounts**.
3. Tap an account, and **Remove account**.

# Camera

You can easily take photos or record videos with your tablet.

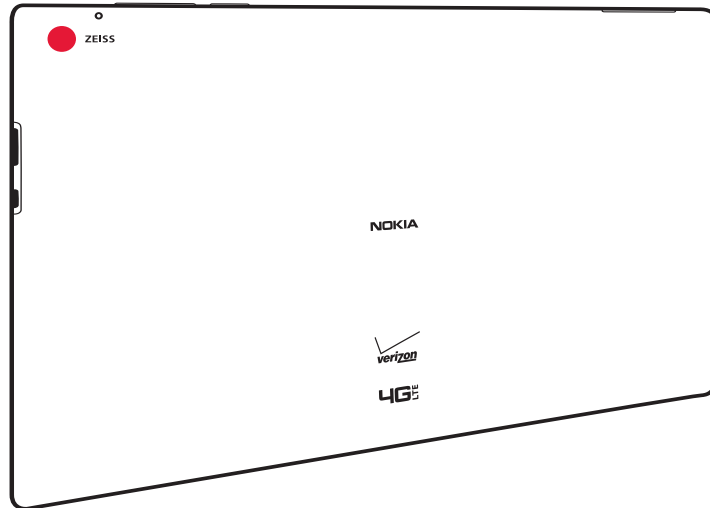

## Take a photo

Capture the best moments with your tablet.

1. Tap .

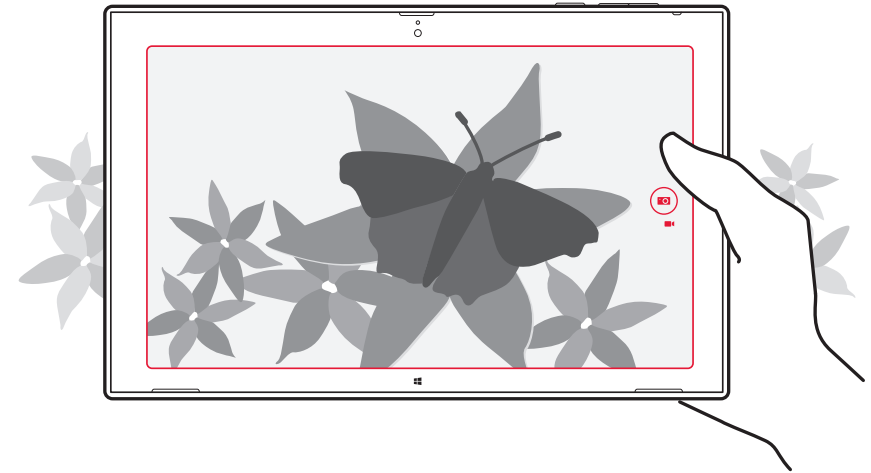

2. To take a photo, tap .



 **Tip:**

---

Organize your photos and videos with Nokia Storyteller. Nokia Storyteller creates a story of the photos and videos based on their time and location.

---

## Take a self-portrait

Swipe up from the bottom of the screen, and tap  **Change camera**. To take the photo, tap .





## View the photo you just took

Tap .

The photos are saved to Camera Roll in the Photos hub.

## Record a video

Besides taking photos with your tablet, you can also capture videos.

1. Tap .
2. To switch from photo to video mode, tap .
3. To start recording, tap . The timer starts to run.
4. To stop recording, tap . The timer stops.

The videos are saved to Camera Roll in the Photos hub.

### Tip:

---

Edit your videos with Nokia Video Director, and create your own fun video shows.

---

## Photos hub

The photos you've taken or videos you've recorded with your tablet are saved to the Photos hub, where you can browse and view them.

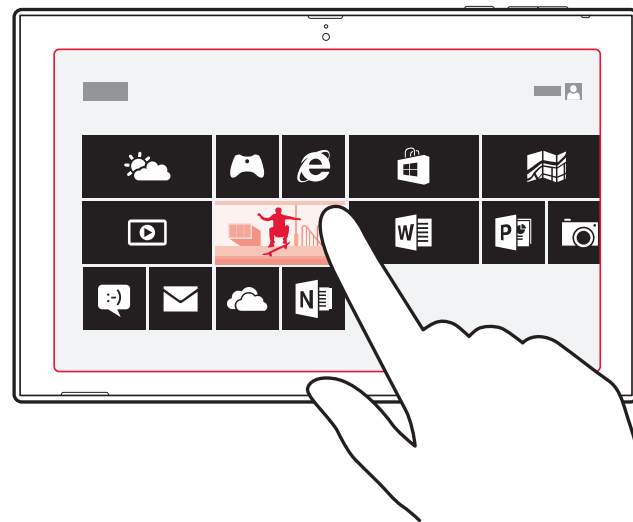

You can also import photos and videos from other compatible devices, such as a phone, or share them with your friends and family.

## View photos and videos

Relive those important moments – view the photos and videos on your tablet.

1. Tap  **Photos**.
2. To view a photo or video you've taken with the tablet, tap **Camera Roll** and the photo or video.
3. To view the next photo or video, swipe left. To view the previous photo or video, swipe right.

### Tip:

---

To view the photos and videos as thumbnails, place 2 fingers on the screen, and slide them together.



---

## Zoom in or out

In the full screen view, place 2 fingers on the screen, and slide them apart or together.

## Share photos and videos

Want to share your photos and videos for your friends and family to see? You can do that directly from the Photos hub.



1. Tap  **Photos**, and browse to your photos and videos.
2. Tap and drag down the photos and videos you want to share.
3. Swipe in from the right of the screen, and tap  **Share**.
4. Select how you want to share, and follow the instructions shown on the screen.

### Tip:

To quickly share with someone close by, use Tap and send. Select the photos or videos you want share, swipe in from the right of the screen, tap  **Devices > Tap and send**, and touch the other device with your tablet. The other device needs to support NFC.

## Change the background of the Photos tile

Have a superb shot that makes you feel good every time you look at it? Set it as the background of the Photos hub tile.

1. Tap  **Photos**, and browse to the photo.
2. In the full screen view, swipe up from the bottom of the screen, and tap  **Set as > Photos tile**.

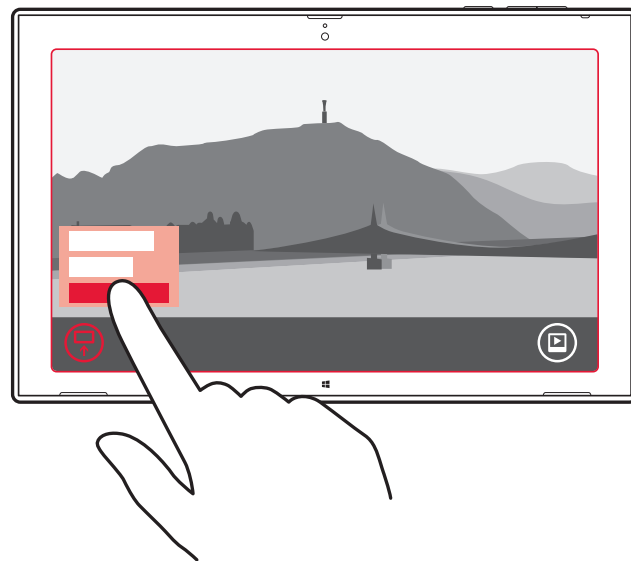

### Tip:

To shuffle photos on the Photos hub tile, swipe in from the right of the screen, tap  **Settings > Options**, and turn **Shuffle photos on the Photos tile On** .



## Import your photos and videos

You can import photos and videos from your phone, camera, or other device, and see them straight away in the Photos hub.

1. Tap  **Photos**.
2. Connect your device to your tablet with a compatible USB cable. Make sure the device is turned on.
3. Swipe up from the bottom of the screen, and tap  **Import**.
4. Select the device, and tap the files to import.

 **Tip:**

---





By default, the app selects the files that are not yet imported. To select other files, tap **Clear selection**, and tap the files you want to import.

---

5. Write a name for the folder, if you like, and tap  **Import**.

## Edit a photo

You can do quick edits, such as rotate and crop, to the photos you have taken.

1. Tap  **Photos**.
2. Tap **Camera Roll** and the photo you want to edit.
3. In the full screen view, swipe up from the bottom of the screen, and tap  **Edit**.
4. When you have edited the photo, swipe up from the bottom of the screen, and tap  to save a copy, or  to update the original photo.

The photos are saved to Camera Roll in the Photos hub.

# Maps & navigation

Explore what's out there and how to get there.

## Turn location services on

Find out where you are using HERE Maps, and save your location to the photos you take – let apps use your location info to offer you a wider variety of services.

1. From the Start screen, swipe in from the right of the screen, and tap  **Settings** > **Change PC settings** > **Privacy** > **Location**.
2. Turn **Let Windows and apps use my location On** .

## HERE Maps

HERE Maps shows you where you are and what is nearby.

You can:

- Explore nearby places, such as restaurants and shopping centres and search for addresses and places of interest, such as restaurants, hospitals, and airports
- Get driving, walking, and public transport directions – use your current location or any other place as the start point
- Download maps to your tablet so you can use HERE Maps offline
- Have your favorite places backed up and at hand on all HERE apps and at **here.com** – save places to your Nokia account

Contents of digital maps may sometimes be inaccurate and incomplete. Never rely solely on the content or the service for essential communications, such as in emergencies.



Using services or downloading content may cause the transfer of large amounts of data, which may result in data costs.

Some content is generated by third parties and not Nokia. The content may be inaccurate and is subject to availability.

## Download and update maps

Save new maps to your tablet before a journey, so you can browse the maps without an Internet connection when travelling.

To download and update maps, turn Wi-Fi networking on.

1. Tap  **HERE Maps**.
2. Swipe in from the right of the screen, and tap  **Settings** > **Download maps**.
3. Select the country or region.

## Update an existing map

In the Download maps view, tap **Update my maps**.

## Delete a map

In the Download maps view, tap the map and  **Delete**.

## See where you are on a map

If you need to get your bearings, check where you are on a map. You can also explore different cities and countries.

1. Tap  **HERE Maps**.

 shows where you are. If HERE Maps can't find your location,  shows your last known location.

If accurate positioning is not possible, a green halo around the location icon shows the general area you might be in. In densely populated areas, the accuracy of the estimate is better, and the green halo is not as wide.

2. To see your current or last known location, tap .

 **Tip:**

Trying to get oriented in a new place? When the compass is turned on, the map rotates, so that you can always see which direction you're facing. Tap .

The compass has limited accuracy. Electromagnetic fields, metal objects, or other external circumstances may also affect the accuracy of the compass. The compass should always be properly calibrated.

If the compass needs to be calibrated, follow the instructions on your tablet.

Map coverage varies by country and region.



## Browse the map

Drag the map with your finger.

## Zoom in or out

Place two fingers on the map, and slide your fingers apart or together.

 **Tip:**

To add zoom controls to the map view, swipe in from the right of the screen, tap  **Settings** > **Map options**, and turn **Zoom controls On** .

## Find a location

HERE Maps helps you find specific locations and businesses.

1. Tap  **HERE Maps**.

2. Swipe down from the top of the screen, and tap .

3. Write search words, such as your destination's street address or place name, in the search box.

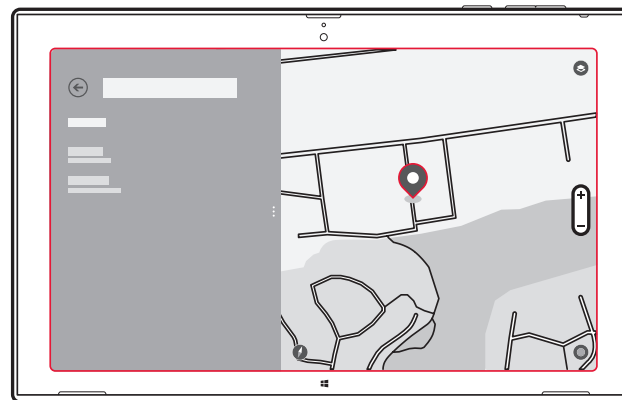

4. Tap .

The location is shown on the map.









## Discover nearby places

Looking for a new restaurant, hotel, or shop? HERE Maps suggests nearby places for you.

1. Tap  **HERE Maps**.
2. Tap  to find suggested places nearest to you, or browse to a point on the map.
3. Tap a category icon on the left.

The nearby places in the category are shown in a list and on the map. To switch between the list and map view, drag the screen divider left or right.

-  Popular
-  Eat & Drink
-  Going Out
-  Shopping
-  Sights & Museums
-  Accommodation

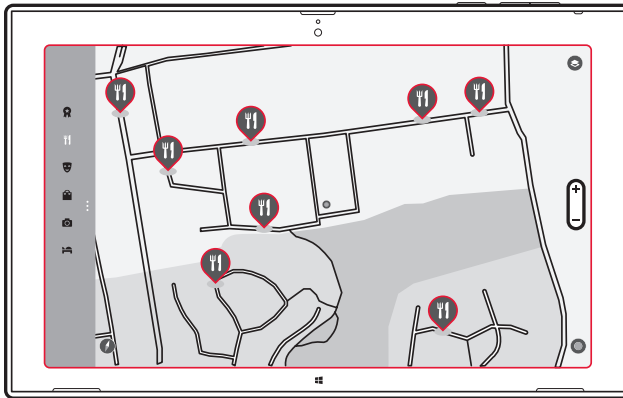





### Tip:

Want to see more info about a place? Tap the place on the list or map. The place details view can contain, for example, contact info, photos, and reviews.

## Get directions to a place

Want to find your way easily? Get directions for walking, driving, or using public transport – use your current location or any other place as the start point.





1. Tap  **HERE Maps**.
2. Swipe down from the top of the screen, and tap **Directions**.
3. If you don't want the start point to be your current location, tap the start point to edit it.
4. Tap the destination box, and search for a destination.
5. Instead of walking , you can drive , or use public transport  (if available in your city).

Your route is shown on a map. To see a list of each turn along your route, drag the screen divider to the right. To see a certain turn on the map, tap the turn.



## Save a place

Before a trip, you might find it handy to save info about hotels, attractions, or petrol stations. Create collections for your saved places to keep them organized.

1. Tap  **HERE Maps**.
2. To search for an address or place, swipe in from the right of the screen, and tap .
3. When the place is shown on the map, swipe up from the bottom of the screen, and tap  **Collect**.
4. Select the collection to which you want to add the place. To create a new collection, tap  **Create**.

### **Tip:**

---

Have your favorite places backed up and ready to hand. If you're signed in to your Nokia account, your saved places and collections are synced automatically to your account. To sign in, swipe in from the right of the screen, and tap  **Settings** > **Sign in**.

---

## View your collections

Swipe up from the bottom of the screen, and tap **Collections**.



### Remove a saved place from a collection

Swipe up from the bottom of the screen, and tap **Collections**. Tap a collection and a place, swipe up from the bottom of the screen, and tap **Remove**.

To remove an entire collection, in the Collections view, tap a collection, swipe up from the bottom of the screen, and tap **Delete collection**.

### Change the look of the map

View the map in different modes, to highlight certain details and to help you find your way more easily.

1. Tap  **HERE Maps**.
2. Tap  and a map view, for example, **satellite** or **transit**.

The available options and features may vary by region.

## Positioning methods

Your tablet shows your location on the map using GPS, GLONASS, A-GPS, Wi-Fi, or network (Cell ID) based positioning.

The availability, accuracy and completeness of the location info depend on, for example, your location, surroundings, and third party sources, and may be limited. Location info may not be available, for example, inside buildings or underground. For privacy info related to positioning methods, see the Nokia Privacy Policy.

The Assisted GPS (A-GPS) network service and other similar enhancements to GPS and Glonass retrieve location info using the cellular network, and assists in calculating your current location.

A-GPS and other enhancements to GPS and GLONASS may require transferring small amounts of data over the cellular network. If you want to avoid data costs, for example when traveling, you can turn the mobile data connection off.

Wi-Fi positioning improves positioning accuracy when satellite signals are not available, especially when you are indoors or between tall buildings. If you're in a place where the use of Wi-Fi is restricted, you can turn Wi-Fi off.

To turn a connection off, swipe in from the right of the screen, and tap **⚙ Settings > Change PC settings > Network > Airplane mode**.

### Note:

---

Using Wi-Fi may be restricted in some countries. For example, in the EU, you are only allowed to use 5150–5350 MHz Wi-Fi indoors, and in the USA and Canada, you are only allowed to use 5.15–5.25 GHz Wi-Fi indoors. For more info, contact your local authorities.

---

The trip meter may not be accurate, depending on the availability and quality of your satellite connection.

# Internet

Learn how to create wireless connections and browse the web while keeping your data costs down.

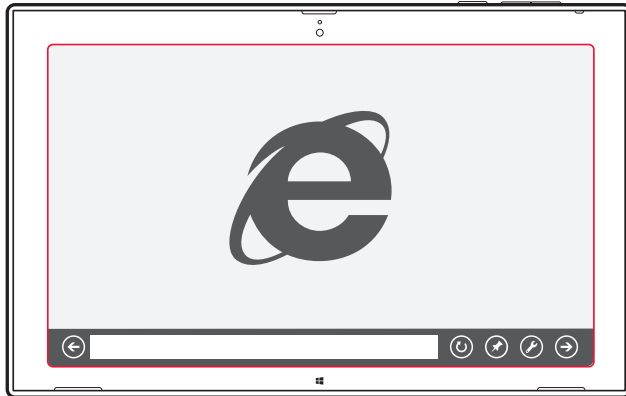

## Define how your tablet connects to the web

Does your network service provider charge you a fixed fee for data transfer or on a pay-as-you-use basis? Change the Wi-Fi and mobile broadband settings to reduce your data costs while roaming and at home.

If both Wi-Fi and mobile broadband connections are available, your tablet uses the Wi-Fi connection.

Swipe in from the right of the screen, and tap **Settings** > **Cellular**.

1. Turn **Wi-Fi On** **☑**.
2. Select the connection you want to use.

## Use a mobile broadband connection

Turn **Mobile broadband On** **☑**.

Connecting to the web when roaming, especially when abroad, can raise data costs substantially. Data roaming means using your tablet to receive data over networks that your network service provider doesn't own or operate.

## Web browser

Catch up on the news, and visit your favorite websites. You can use Internet Explorer on your tablet to view web pages on the Internet. Your browser can also help warn you against security threats.

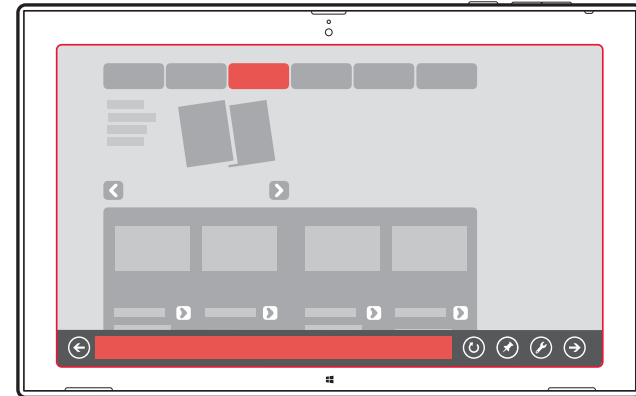

Tap **Internet Explorer**.



To browse the web, you must be connected to the Internet.

## Browse the web

It's fun and easy to browse the web with the Internet Explorer app. If you want to benefit from everything your browser has to offer, you can use the desktop version.

### 💡 Tip:

If your network service provider doesn't charge you a fixed fee for data transfer, to save on data costs, use a Wi-Fi network to connect to the Internet.

1. Tap  **Internet Explorer**.
2. Swipe up from the bottom of the screen.
3. Tap the address bar.
4. Write a web address in the address bar, and tap , or select a website from your pinned, frequent, or favorite websites.

### 💡 Tip:

To search the Internet, write a search word in the address bar, and tap .

## Zoom in or out

Place 2 fingers on the screen, and slide your fingers apart or together.

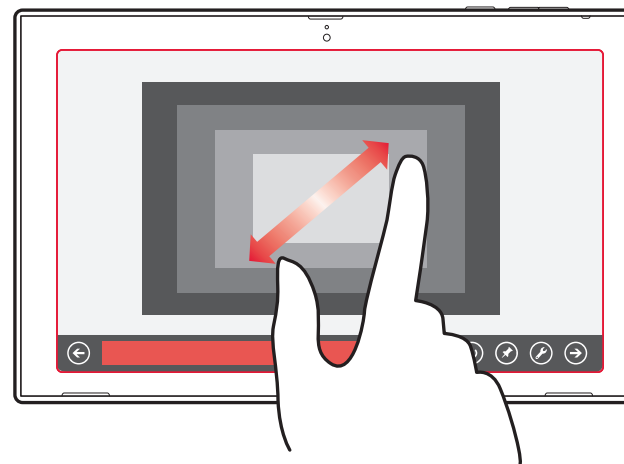

### 💡 Tip:

You can also double-tap the screen.

## Use the desktop version of the browser

Swipe up from the bottom of the screen, and tap  > **View in the desktop**.

## Open a new tab

When you want to visit several websites at the same time, you can open several browser tabs and switch between them.

Tap  **Internet Explorer**.

Swipe up from the bottom of the screen, and tap .

## Switch between tabs

Swipe up from the bottom of the screen, and tap a tab thumbnail.



## Close a tab

Swipe up from the bottom of the screen, and tap **X** at the bottom of the tab thumbnail.

## Add a website to your favorites

If you visit the same websites regularly, add them to your favorites so you can access them quickly.

Tap  **Internet Explorer**.

1. Go to a website.
2. Swipe up from the bottom of the screen, and tap  >  > **Add**.

 **Tip:**

You can also pin your favorite websites to the Start screen. While browsing a website, swipe up from the bottom of the screen, and tap  >  > **Pin to Start**.

## Go to a favorite website

Swipe up from the bottom of the screen, and tap  and a website.

## Clear the browser history

When you've finished browsing, you can delete your private data, such as your browsing history.

1. Swipe in from the right of the screen, and tap  **Settings**.
2. Tap **Options**, and under **History**, tap **Select**, then select what you want to delete, and tap **Delete**.

A cache is a memory location that is used to store data temporarily. If you have, or have tried to, access confidential info or a secure service, requiring passwords, clear the cache after each use.

## Close all network connections

Save your battery by closing Internet connections that are open in the background. You can do it without closing any apps.

Swipe in from the right of the screen, and tap  **Settings** > .

Turn **Airplane mode On** .

All wireless communication on your tablet is stopped.

## Close a Wi-Fi connection

Turn **Wi-Fi Off** .

## Close the mobile broadband connection

Turn **Mobile broadband Off** .

# Entertainment



Having a spare moment and in need of entertainment? Learn how to watch videos, listen to your favorite music, and play games.

## Watch & Listen

You can use your tablet to watch videos and listen to music and podcasts while on the move.

## Play music and podcasts

Have your favorite media with you while on the move – listen to music and podcasts wherever you are.

1. Tap  **Music**.
2. Tap **Collection**.
3. Tap **Albums**, **Artist**, or **Songs**.
4. Tap the song you want to play.
5. Tap .

## Pause or resume playback

Tap  or .

## Skip to the next or previous song

Tap  or .

## Fast-forward or rewind

Drag the slider.

## Play videos

Keep your entertainment at hand, and watch your favorite videos wherever you go.

1. Tap  **Video**.
2. Swipe to **personal videos**.
3. Tap the video you want to play.

 **Tip:**

---

The videos you record with your tablet are saved to the Photos hub.

---

## Pause or resume playback

Tap  or .

## Fast-forward or rewind

Drag the slider.

## Get started with the Nokia Music app

With Nokia Music, you can discover new music and listen to your old favorites.

You can download Nokia Music for free from Windows Store. To get the full features, you can buy a Nokia Music + membership.

### Tip:

---

If you allow Nokia Music to run in the background, you can get notifications and artist images on your lock screen.

---

This service is not available in all countries or regions.

## Mix Radio

The easiest way to check out new artists and songs in different genres is to stream music from Nokia Mix Radio. You can stream hand-picked mixes from different artists and genres and save them on your device to enjoy offline.

If you do not have a valid Nokia MixRadio+ subscription, Mix radio only plays the first 30 seconds of each song in the mix.

1. Open **Nokia Music**.
2. Tap the mix you want to listen to. To see all available mixes, tap **see all**.

### Tip:

---

To search for mixes with your favorite artists, swipe in from the right of the screen, and tap .

---

## Pause or resume music

Tap  or .

## Skip to the next song

Tap .

There may be a limit to how many songs you can skip.

## Create a mix

With Nokia Mix Radio, you can create personalized mixes to get music recommendations in line with your favorite artists.

1. Open **Nokia Music**.
2. Tap **create a mix**.
3. Write an artist name – you can add up to 3 names.
4. Tap  to create a mix based on the selected artists.

## Take a mix offline

Enjoy mixes even when offline, and download them to your device.

1. Open **Nokia Music**.
2. Drag the mix down, and tap  **Take offline**.
3. To listen to the mix, swipe to **Offline mixes**, and tap the mix.

You can only have a limited number of mixes offline.

## Delete an offline mix

Drag the mix down, and tap  **Delete**.

## Buy music from Nokia Music

Discovered a great new song with Mix radio? Buy it, so you can listen to it whenever you want.

1. Open **Nokia Music**
2. While listening to Mix radio, swipe up from the bottom of the screen, and tap . Some songs can only be downloaded as part of an album.

### **Tip:**

---

You can also tap a song in the recently played list to buy it.

---

3. If asked, sign in to your Nokia account.
4. Select a payment method, and follow the instructions on the screen.

## Play music

With My music, you can easily manage your music collection.

1. Open **Nokia Music**.
2. Swipe to **My music**.
3. Tap a song, album, artist, or genre to add it to the queue.
4. Tap **Play selected**.

### **Tip:**

---

When listening to a song, tap the name of the artist to find out more about them.

---

## Pause or resume playback

Select  or .

To play songs in a random order, tap .

## Skip to the next or previous song

Tap  or .

## Windows Store

Do you want to personalize your tablet with more apps? Or download games, also free of charge? Browse the Windows Store to find the latest content for you and your tablet.

You can download:

- Apps
- Games

You can also:

- Get content that is relevant to your tastes and location
- Share recommendations with your friends

The availability of Windows Store and the selection of items available for download depend on your region.

To download from Windows Store, you need to be signed in to your Microsoft account on your tablet. When you're signed in, you are offered content compatible with your tablet.

Many items are free of charge; some you need to pay for with your credit card or on your operator bill.

The availability of payment methods depends on your country of residence and your network service provider.

Using services or downloading content may cause the transfer of large amounts of data, which may result in data costs.

## Browse or search Store

Check out the latest and most downloaded apps, games, and other items recommended for you and your tablet. Browse different categories, or search for specific items.

Tap  **Store**.



## View or browse categories

Swipe left or right to browse through the categories, and tap a category title to see more items in the category.

Tap an item to view its details.

## Search Store

Tap the search field at the top right of the screen, write your search words, and tap .

## Download an app, game, or other item

Download free apps, games, or other stuff, or buy more content for your tablet.

1. Tap  **Store**.
2. Tap an item to view its details.
3. If the item has a price, tap **Buy**. If the item is free, tap **Install**. The availability of payment methods depends on your country of residence and your network service provider.
4. If you're not signed in to your Microsoft account, sign in now.
5. Follow the instructions shown on your tablet.

When the download is complete, you can open or view the item, or continue browsing for more content. The content type determines where the item is stored on your tablet.

For more info on an item, contact the publisher of the item.



**Tip:**

---

Use a Wi-Fi connection to download large files.

---

## View your download queue

While an item is downloading, you can continue to browse Windows Store for other content and add items to your download queue.

1. Tap  **Store**.
2. To view your download queue, tap the installation notification at the top right of the screen.

The notification shows the number of items being downloaded.

One item is downloaded at a time, and pending items wait in your download queue.



**Tip:**

---

If you need to, for example, temporarily close your Internet connection, tap the downloading item and **Pause download**. To resume downloading, tap **Resume download**. Pause pending items individually. If a download fails, you can re-download the item.

---

## Write a review for an app

Do you want to share your opinion on an app with other Windows Store users? Rate and review the app. You can post one review for each app you've downloaded.

1. Start the app you want to review.
2. Swipe in from the right of the screen, and tap  **Settings > Rate and review**.
3. Rate the app, and write your review, then tap **Submit**.



**Tip:**

---

Besides apps, you can rate and review your other downloaded items in the same way.

---

## Games

Want to have some fun? Keep yourself entertained by downloading and playing games on your tablet.

### Download games

Get new games on your tablet on the go from Windows Store.

1. Tap  **Store**.
2. Swipe down from the top of the screen, tap **Games**, browse the selection, and tap the game you want.
3. To download a free game, tap **Install**.
4. To try a game for free, tap **Try**, if available.
5. To buy a game, tap **Buy**.

The availability of payment methods depends on your country of residence and your network service provider.

#### **Tip:**

---

To play a game you've downloaded, on the Start screen, swipe up to the Apps menu, and tap the game tile.

---

# Office

Keep yourself organized. Learn how to use the calendar and Microsoft Office apps.



## Microsoft Office

Microsoft Office for your tablet is your office away from the office.

With Microsoft Office apps, you can use your tablet to create and edit Word documents and Excel workbooks, open and view PowerPoint slide shows, and create notes with OneNote.



You can also save your documents to Windows SkyDrive. SkyDrive is cloud storage that you can use to access your documents from your tablet, phone, computer, or Xbox. When you stop working on a document, and go back to it later, you're in the same place where you left it – no matter which device you're using.

Microsoft Office consists of the following:

- Microsoft Word
- Microsoft Excel
- Microsoft PowerPoint
- Microsoft OneNote
- Windows SkyDrive

## Create a Word document

You can create new documents with Microsoft Word.

1. Tap  **Word**.
2. Tap a template.
3. Write your text.
4. To save your document, tap .

 **Tip:**



---

To save your document to SkyDrive, tap **FILE > Save As > SkyDrive**. You must be signed in to your Microsoft account to use SkyDrive.

---

## Edit a Word document

Polish your documents on the road with Microsoft Word. You can edit the documents and share your work on a SharePoint site.

1. Tap  **Word**.
2. If you have created the document recently, it's listed under **Recent**. Tap the document.
3. If you can't find the document under **Recent**, tap **Open other documents**, and locate the file. Then tap the file and **Open**.
4. Edit the document.
5. To save your document, tap .

 **Tip:**

---

To access an important document quickly, you can pin it to the Recent list. Tap and hold the document, and tap **Pin to list**.

---

## Add a comment



At the top of the screen, tap **INSERT > Comment**.

## Search for text in a document

At the top of the screen, tap **HOME > Find**.

## Create an Excel workbook

With Microsoft Excel, you can create new Excel workbooks.

1. Tap  **Excel**.
2. Tap the blank workbook or a template.
3. Tap a cell, then tap the text box above the workbook.
4. Type in values or text.
5. To save your workbook, tap .

 **Tip:**



---

To save your workbook to SkyDrive, tap **FILE > Save As > SkyDrive**. You must be signed in to your Microsoft account to use SkyDrive.

---

## Create a PowerPoint presentation

You can create a new presentation with Microsoft PowerPoint.

1. Tap  **PowerPoint**.
2. Tap a template.
3. Create your presentation.
4. To add a slide, tap the place on the left side of the screen where you want to add the slide, and tap **New Slide**.
5. To save your presentation, tap .

 **Tip:**

---

To save your presentation to SkyDrive, tap **FILE > Save As > SkyDrive**. You must be signed in to your Microsoft account to use SkyDrive.

---

## View and edit a PowerPoint presentation

Add the finishing touches to your presentation en route to your meeting with Microsoft PowerPoint.

1. Tap  **PowerPoint**.
2. If you have created the presentation recently, it is listed under **Recent**. Tap the presentation.
3. If you can't find the presentation under **Recent**, tap **Open Other Presentations** and locate the file. Then tap the file and **Open**.
4. Edit the slides.

To go to a specific slide, tap the slide in the list on the left.

 **Tip:**

---

To add a comment to a slide, at the top of the screen, tap **INSERT > Comment**.

---

5. To save your presentation, tap .

**Tip:**

To save your presentation to SkyDrive, tap **FILE > Save As > SkyDrive**. You must be signed in to your Microsoft account to use SkyDrive.



**Watch a PowerPoint broadcast**

You can attend a meeting on the go and watch a PowerPoint presentation broadcast over the Internet on your tablet.

Open the mail containing the link to the broadcast presentation, and tap the link.

**Write a note**

Notes on paper are easy to lose. Instead of jotting them down on paper, you can write your notes with Microsoft OneNote. This way, you always have your notes with you. You can also sync your notes to SkyDrive and view and edit them with OneNote on your tablet, on your computer, or online in a web browser.

1. Tap  **OneNote**.
2. Tap anywhere on the page to start writing a note.
3. To add a new section, tap the **+** tab above the page.
4. To add a new page within the section, tap .



**Calendar**

Learn how to keep your appointments, tasks, and schedules up to date.

**Add an appointment**

Need to remember an appointment? Add it to your calendar.

You must be signed in to your Microsoft account to use the calendar.

1. Tap  **Calendar**.
2. Swipe down from the top of the screen, and tap  **Month**.
3. Swipe left or right to find the right month, and tap the day of the appointment.
4. Fill in the fields.
5. To add a reminder, tap **Show more**, and under **Reminder**, set the reminder time.
6. Tap .

**Delete an appointment**

Tap the appointment and .

# Device management & connectivity

Take care of your tablet and its contents. Learn how to connect to accessories and networks, transfer files, create backups, lock your tablet, and keep the software up to date.

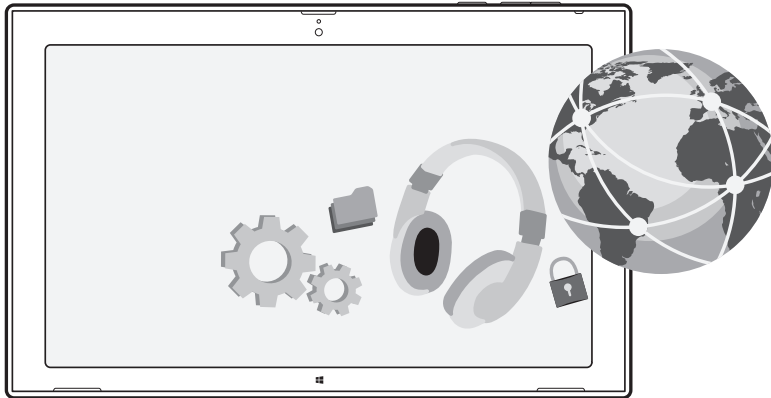

## Keep your tablet up to date

Learn how to update your tablet software and apps.

### Update your tablet software

No computer needed – update your tablet software and apps wirelessly for new features and improved performance. By default, your tablet automatically checks for updates daily, and downloads and installs the updates found.

Before starting the update, connect a charger or make sure your tablet has enough battery power.

Your tablet needs to connect to the Internet. The size of the update may be big, and if you don't have a data plan, the data transmission costs may pile up quickly. For info about possible data costs, contact your network service provider.

#### **Warning:**

---

If you install a software update, you cannot use the device until the installation is completed and the device is restarted.

---

1. Swipe in from the right of the screen, and tap **Settings** > **Change PC settings** > **Update and recovery** > **Windows Update**.
2. Tap **Check now**.
3. To download and install an update, tap **View details** > **Install**.

### Update your apps

Tap **Store**. Swipe in from the right, and tap **Settings** > **App updates**. Tap **Check for updates** > **Install**.

## Bluetooth

You can connect wirelessly to other compatible devices, such as phones, headsets, mice, and keyboards. You can also send your photos to compatible phones or to your computer.

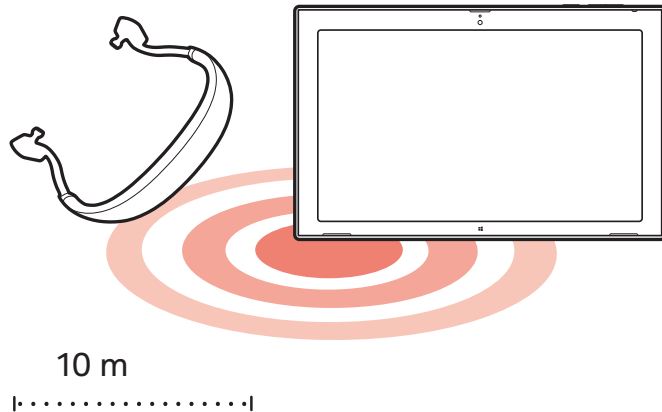

To turn Bluetooth on, swipe in from the right of the screen, and tap **Settings** > **Change PC settings** > **PC and devices** > **Bluetooth**. Then turn **Bluetooth On**.

Since devices with Bluetooth wireless technology communicate using radio waves, they do not need to be in direct line-of-sight. However, they must be within 33 feet (10 meters) of each other, although the connection may be subject to interference from obstructions such as walls or from other electronic devices.

Paired devices can connect to your tablet when Bluetooth is turned on. Other devices can detect your tablet only if the Bluetooth settings view is open.

Do not pair with or accept connection requests from an unknown device. This helps to protect your tablet from harmful content.

## Connect to your phone with Bluetooth

Use Bluetooth to wirelessly connect to your phone, to share photos and much more.

1. Swipe in from the right of the screen, and tap **Settings** > **Change PC settings** > **PC and devices** > **Bluetooth**.
2. Turn **Bluetooth On**.
3. Make sure Bluetooth is turned on in your phone.
4. Make sure the devices are visible to each other.

You may need to start the pairing process from the phone. For details, see your phone user guide.

5. You can see the Bluetooth phones within range. Tap the phone you want to connect to.
6. If the phone needs a passcode, type in or accept the passcode.

The passcode is only used when you connect to something for the first time.

## Connect to a wireless headset

With a wireless headset (sold separately), you can listen to music free from cables.

1. Swipe in from the right of the screen, and tap **Settings** > **Change PC settings** > **PC and devices** > **Bluetooth**.
2. Turn **Bluetooth On**.
3. Make sure the headset is on.

You may need to start the pairing process from the headset. For details, see your headset user guide.

4. To pair your tablet and the headset, tap the headset in the list.
5. You may need to type in a passcode. For details, see your headset user guide.

## NFC

Explore the world around you. Tap accessories to connect to them, or tap tags to open websites. Near Field Communication (NFC) makes connecting easy and fun.

With NFC, you can:

- Connect to compatible Bluetooth accessories that support NFC, such as a headset or a wireless speakerphone
- Send things, such as contacts or your own photos, to your friend's tablet, phone, or PC running on Windows 8, with Tap and send
- Tap tags to get more content for your tablet, or to access online services

The NFC area is on the back of your tablet, near the camera. Tap other tablets, phones, accessories, or tags with the NFC area.

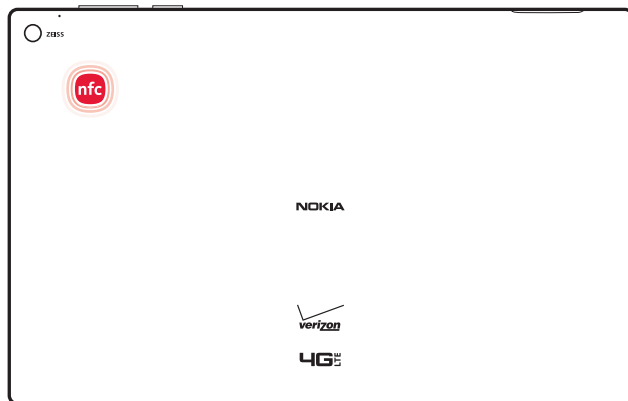

Before using NFC, make sure the screen is unlocked.

### Turn NFC on

With NFC, you can connect to other compatible tablets, phones, and accessories just by tapping them with your tablet.

1. Swipe in from the right of the screen, and tap **Settings** > **Change PC settings** > **Network** > **Airplane mode**.
2. Turn **NFC On** .

## Read NFC tags

NFC tags can contain info, such as a web address, phone number, or business card. The info you want is just a tap away.

Tap a tag with the NFC area of your tablet.

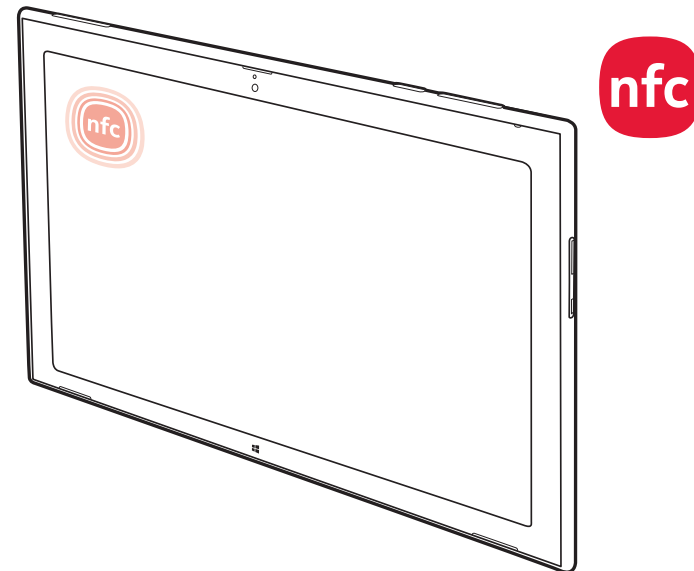



## Memory and storage

Learn how to manage your photos, apps, and other stuff on your tablet.

### Check available memory

Want to check how much memory you have available? You can also set where to save your files in the future.

1. Swipe in from the right of the screen, and tap **Settings** > **Change PC settings** > **Search and apps** > **App sizes**.
2. Under **App sizes**, you can see the amount of available memory.

If you're running out of space, first check for and remove things you no longer need:

- Text, multimedia, and mail messages
- Contact entries and details
- Apps
- Music, photos, videos, or other files

#### Tip:

To free up storage space on your tablet, you can store your photos, documents, and other stuff on SkyDrive instead of your tablet. You can download the stuff back to your tablet when you need it.

## Remove an app from your tablet

You can remove installed apps that you no longer want to keep or use, to increase the amount of available memory.

1. From the Start screen, swipe up from the bottom of the screen, and tap **Customize**.
2. Tap the app.
3. Tap  **Uninstall**.

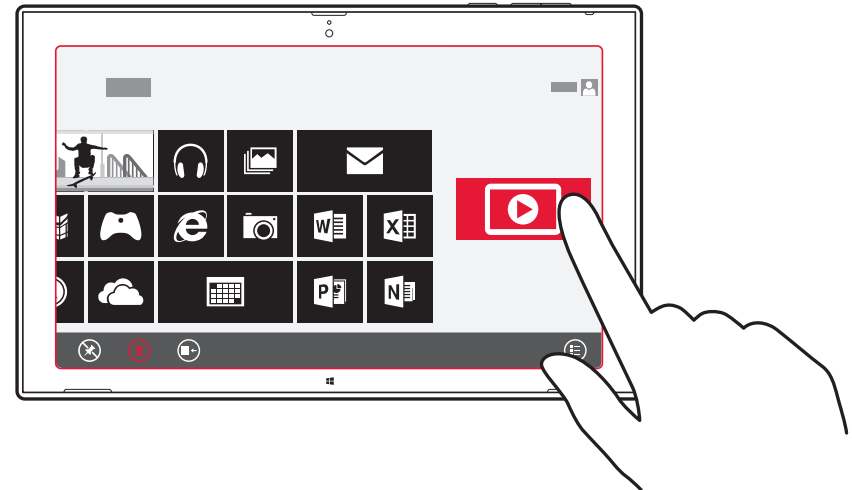

If you remove an app, you may be able to reinstall without buying again, as long as the app is available in Windows Store.

If an installed app depends on a removed app, the installed app may stop working. For details, see the user documentation of the installed app.

Not all apps can be removed.

## Security

Learn how to protect your tablet, and how to keep your data secure.

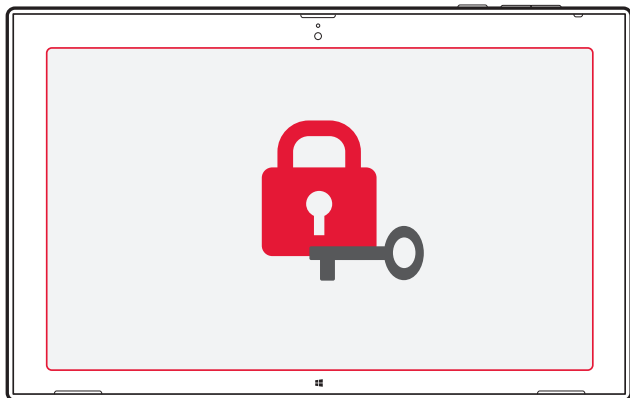

### Lock your tablet

Want to protect your tablet against unauthorized use? Define a password, and set your tablet to lock itself automatically when you're not using it.

1. Swipe in from the right of the screen, and tap **Settings** > **Change PC settings** > **Accounts** > **Signin options**.
2. Tap **Add**, and follow the instructions shown.

Keep your password secret and in a safe place separate from your tablet. If you forget your password, and cannot recover it, your tablet will require service. Additional charges may apply, and all the personal data on your tablet may be deleted. For more info, contact Nokia Care or your tablet dealer.

 **Tip:**

You can also create a 4-digit PIN code, and use that instead of the password. Tap **Settings** > **Change PC settings** > **Accounts** > **Signin options**. Under **PIN**, tap **Add**.

### Unlock your tablet

Press the Power/Lock key, drag the lock screen up, and type in your password.

 **Tip:**

If you have created a picture password or a PIN code, you can quickly change which to use. When unlocking the tablet, just tap **Sign-in options** and the method you want to use.

### Create a picture password

Want to create a password that's really you? You can use your favorite picture as your password.

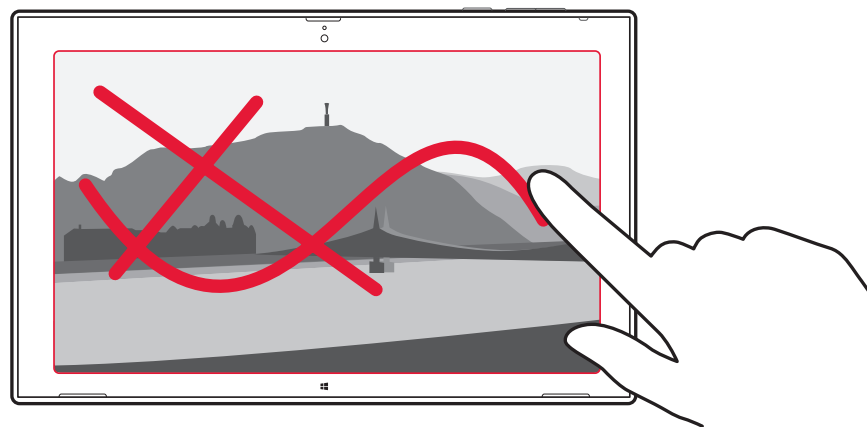

You need to create a password for your tablet before you can create a picture password.

1. Swipe in from the right of the screen, and tap **Settings** > **Change PC settings** > **Accounts** > **Signin options**.
2. Under Picture password, tap **Add**, and follow the instructions shown.

You can sign in with your normal password even though you have created a picture password. Just tap **Sign-in options** when signing in.

## Remove the picture password

Swipe in from the right of the screen, and tap **Settings > Accounts > Sign-in options**, and under **Picture password**, tap **Remove**.

## Change your PIN code

If your SIM card came with a default PIN code, you can change it to something more secure.

1. Swipe in from the right of the screen, and tap **Settings > Change PC settings > Network > Connections**.
2. Tap the mobile broadband network name.
3. Under **Security**, tap **Change PIN**.

The PIN code can be 4-8 digits.

## Access codes

Ever wondered what the different codes on your tablet are for?

PIN code (4-8 digits)	<p>This protects your SIM card against unauthorized use or is required to access some features.</p> <p>You can set your tablet to ask for the PIN code when you turn it on.</p> <p>If not supplied with your card or you forget the code, contact your network service provider.</p> <p>If you type in the code incorrectly 3 times in a row, you need to unblock the code with the PUK code.</p>
PUK	<p>This is required to unblock a PIN code.</p> <p>If not supplied with your SIM card, contact your network service provider.</p>

Security code (lock code, password)	<p>This helps you protect your tablet against unauthorized use.</p> <p>You can set your tablet to ask for the lock code that you define.</p> <p>Keep the code secret and in a safe place, separate from your tablet.</p> <p>If you forget the code and your tablet is locked, your tablet will require service. Additional charges may apply, and all the personal data on your tablet may be deleted.</p> <p>For more information, contact Nokia Care or your tablet dealer.</p>
IMEI/MEID	<p>This is used to identify tablets in the network. You may also need to give the number to Nokia Care services.</p> <p>To view the number, first make sure the SIM card is in. Then swipe in from the right of the screen, tap <b>Settings &gt; Change PC settings &gt; Network &gt; Connections</b>, and under <b>Mobile broadband</b>, tap the network name. The SIM ICCID appears under <b>Properties</b>.</p>

# Troubleshooting and support

When you want to learn more about your tablet, or if you're unsure how your tablet should work, there are several support channels for you to check.

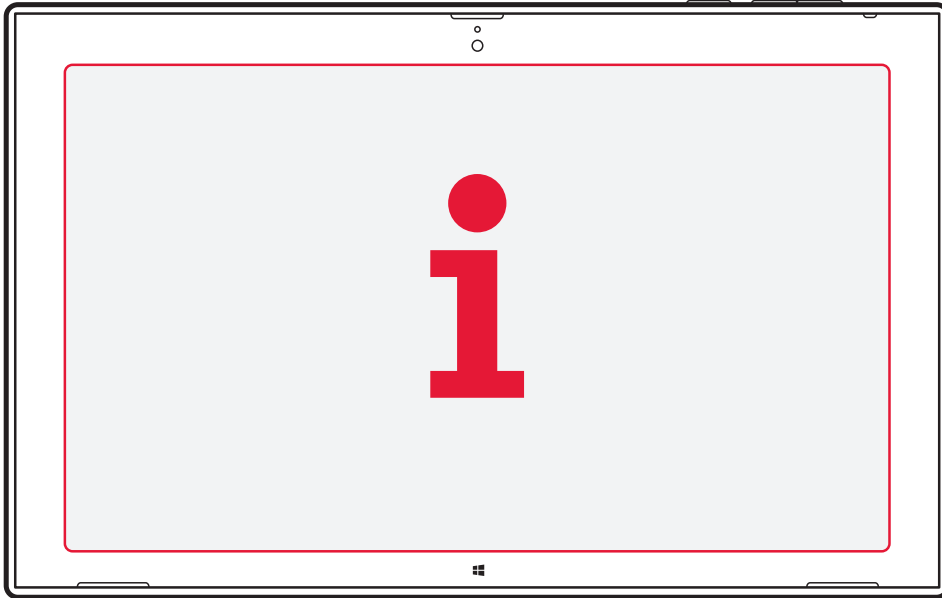

To help you get the most out of your tablet, you can explore [www.nokia.com/support](http://www.nokia.com/support).

There you can find:

- Troubleshooting info
- Discussions
- News on apps and downloads
- Software update info
- Further details about features and technologies, and the compatibility of devices and accessories

Troubleshooting and discussions may not be available in all languages.

For support videos, go to [www.youtube.com/NokiaSupportVideos](http://www.youtube.com/NokiaSupportVideos).

# Product and safety information

You need a subscription with a service provider.

Using some features and downloading content (for example maps or movies) require a network connection and may result in transfer of large amounts of data, and data costs. You may also need to subscribe to some features. Some features may not necessarily be available in all instances, like when roaming.

## Take care of your device

Handle your device, battery, charger and accessories with care. The following suggestions help you keep your device operational.

- Keep the device dry. Precipitation, humidity, and all types of liquids or moisture can contain minerals that corrode electronic circuits. If your device gets wet, let the device dry.
- Do not use or store the device in dusty or dirty areas.
- Do not store the device in high temperatures. High temperatures may damage the device or battery.
- Do not store the device in cold temperatures. When the device warms to its normal temperature, moisture can form inside the device and damage it.
- Do not open the device other than as instructed in this guide.
- Unauthorized modifications may damage the device and violate regulations governing radio devices.
- Do not drop, knock, or shake the device. Rough handling can break it. If you believe the battery or charger is damaged, take it to a service center for inspection before continuing to use it.
- Only use a soft, clean, dry cloth to clean the surface of the device.
- Do not paint the device. Paint can prevent proper operation.
- Keep the device away from magnets or magnetic fields.

- To keep your important data safe, store it in at least two separate places, such as your device, memory card, or computer, or write down important information.
- Handle hard drives with care. Shock, vibration, bumping, and dropping; other mishandling of the device; extreme temperatures; humidity and liquids may cause the hard drive to malfunction and data to be lost or corrupted.

## Recycle



Always return your used electronic products, batteries, and packaging materials to dedicated collection points. This way you help prevent uncontrolled garbage disposal and promote the recycling of materials. All materials of the device can be recovered as materials and energy. Check how to recycle your Nokia products at [www.nokia.com/recycle](http://www.nokia.com/recycle).

## About Digital Rights Management

When using this device, obey all laws and respect local customs, privacy and legitimate rights of others, including copyrights. Copyright protection may prevent you from copying, modifying, or transferring photos music, and other content.

Digital rights management (DRM) protected content comes with an associated license that defines your rights to use the content.

If your device has content protected with either PlayReady or WMDRM, both the licenses and the content are lost if the device memory is formatted. You may also lose the licenses and the content if the files on your device become corrupted. Losing the licenses or the content may limit your ability to use the same content on your device again. For more info, contact your service provider.

## **Battery and charger info**

Your device has an internal, non-removable, rechargeable battery. Do not attempt to open the back cover or remove the battery, as you may damage the device. To replace the battery, take the device to the nearest authorized service facility.

Charge your device with AC-300 charger that comes in box. Charger plug type may vary.

Nokia may make additional battery or charger models available for this device.

The battery can be charged and discharged hundreds of times, but it will eventually wear out. When the talk and standby times are noticeably shorter than normal, to replace the battery, take the device to the nearest authorized service facility.

Only replace the battery with a battery that is compliant with the IEEE 1625 standard.

Only use the battery with a charging system that has been qualified with the system per CTIA Certification Requirements for Battery System Compliance to IEEE 1625.

## **Battery and charger safety**

To unplug a charger or an accessory, hold and pull the plug, not the cord.

When your charger is not in use, unplug it. If left unused, a fully charged battery will lose its charge over time.

Always keep the battery between 59°F and 77°F (15°C and 25°C) for optimal performance. Extreme temperatures reduce the capacity and lifetime of the battery. A device with a hot or cold battery may not work temporarily.

Do not dispose of batteries in a fire as they may explode. Obey local regulations. Recycle when possible. Do not dispose as household garbage.

Do not dismantle, cut, crush, bend, puncture, or otherwise damage the battery in any way. If a battery leaks, do not let liquid touch skin or eyes. If this happens, immediately flush the affected areas with water, or seek medical help. Do not modify, attempt to insert foreign objects into the battery, or immerse or expose it to water or other liquids. Batteries may explode if damaged.

Use the battery and charger for their intended purposes only. Improper use, or use of unapproved or incompatible batteries or chargers may present a risk of fire, explosion, or other hazard, and may invalidate any approval or warranty. If you believe the battery or charger is damaged, take it to a service center before continuing to use it. Never use a damaged battery or charger. Do not charge your device during a lightning storm. Only use the charger indoors.

## **Additional safety information**

### **Small children**

Your device and its accessories are not toys. They may contain small parts. Keep them out of the reach of small children.

### **Medical devices**

Operation of radio transmitting equipment, including wireless phones, may interfere with inadequately shielded medical devices' function. Consult a physician or the medical device's manufacturer to determine if it is adequately shielded from external radio energy.

## Implanted medical devices

To avoid potential interference, manufacturers of implanted medical devices recommend a minimum separation of 6 inches (15.3 centimeters) between a wireless device and the medical device. Persons who have such devices should:

- Always keep the wireless device more than 6 inches (15.3 centimeters) from the medical device.
- Turn the wireless device off if there is any reason to suspect that interference is taking place.
- Follow the manufacturer directions for the implanted medical device.

If you have any questions about using your wireless device with an implanted medical device, consult your health care provider.

## Accessibility solutions

Nokia is committed to making mobile phones easy to use for all individuals, including those with disabilities. For more information, visit the Nokia website at [www.nokiaaccessibility.com](http://www.nokiaaccessibility.com).

## Hearing

### Warning:

---

When you use a headset, your ability to hear outside sounds may be affected. Do not use a headset where it can endanger your safety.

---

Some wireless devices may interfere with some hearing aids.

## Nickel

The surface of this device is nickel-free.

## Protect your device from harmful content

Your device may be exposed to viruses and other harmful content. Take the following precautions:

- Be cautious when opening messages. They may contain malicious software or otherwise be harmful to your device or computer.
- Be cautious when accepting connectivity requests, browsing the Internet, or downloading content. Do not accept Bluetooth connections from sources you do not trust.
- Install antivirus and other security software on your device and any connected computer. Only use one antivirus app at a time. Using more may affect performance and operation of the device and/or computer.
- If you access preinstalled bookmarks and links to third party Internet sites, take the appropriate precautions. Nokia does not endorse or assume liability for such sites.

## Information on health

The U.S. Food and Drug Administration (FDA) and the U.S. Federal Communications Commission (FCC) published statements and questions and answers concerning mobile telephones and health. Nokia encourages you to visit these websites for updated information. You can access the FDA website at [www.fda.gov/Radiation-EmittingProducts/RadiationEmittingProductsandProcedures/HomeBusinessandEntertainment/CellPhones/default.htm](http://www.fda.gov/Radiation-EmittingProducts/RadiationEmittingProductsandProcedures/HomeBusinessandEntertainment/CellPhones/default.htm) and the FCC website at [transition.fcc.gov/oet/rfsafety/rf-faqs.html](http://transition.fcc.gov/oet/rfsafety/rf-faqs.html). Additional health-related information is available from the World Health Organization (WHO) at [www.who.int/mediacentre/factsheets/fs193/en/](http://www.who.int/mediacentre/factsheets/fs193/en/) and The National Cancer Institute (“NCI”) [www.cancer.gov/ncicancerbulletin/NCI\\_Cancer\\_Bulletin\\_092308/page7](http://www.cancer.gov/ncicancerbulletin/NCI_Cancer_Bulletin_092308/page7). In the event that you are concerned about possible health effects, the FDA suggests that you limit your own or your children’s radio frequency (RF) exposure by limiting the length of calls or by using handsfree devices.



## Vehicles

Radio signals may affect improperly installed or inadequately shielded electronic systems in vehicles. For more info, check with the manufacturer of your vehicle or its equipment.

Only qualified personnel should install the device in a vehicle. Faulty installation may be dangerous and invalidate your warranty. Check regularly that all wireless device equipment in your vehicle is mounted and operating properly. Do not store or carry flammable or explosive materials in the same compartment as the device, its parts, or accessories. Do not place your device or accessories in the air bag deployment area.

## Safety and texting while driving

Obey all local laws. Always keep your hands free to operate the vehicle while driving. Your first consideration while driving should be road safety.

Cellular Telecommunications & Internet Association (CTIA) has also published further info and tips on safe driving at [www.ctia.org/consumer\\_info/safety](http://www.ctia.org/consumer_info/safety), which we encourage you to review. Users located in the U.S. may also call 1-888-901-SAFE for more info.

## Potentially explosive environments

Turn your device off in potentially explosive environments, such as near gas station pumps. Sparks may cause an explosion or fire resulting in injury or death. Note restrictions in areas with fuel; chemical plants; or where blasting operations are in progress. Areas with a potentially explosive environment may not be clearly marked. These usually are areas where you are advised to turn your engine off, below deck on boats, chemical transfer or storage facilities, and where the air contains chemicals or particles. Check with the manufacturers of vehicles using liquefied petroleum gas (such as propane or butane) if this device can be safely used in their vicinity.

## Certification information (SAR)

**This mobile device meets international guidelines for exposure to radio waves.**

Your mobile device is a radio transmitter and receiver. It is designed not to exceed the limits for exposure to radio waves (radio frequency electromagnetic fields), recommended by international guidelines from the independent scientific organization ICNIRP. These guidelines incorporate substantial safety margins that are intended to assure the protection of all persons regardless of age and health.

The exposure guidelines are based on the Specific Absorption Rate (SAR), which is an expression of the amount of radio frequency (RF) power deposited in the head or body when the device is transmitting. The ICNIRP SAR limit for mobile devices is 2.0 W/kg averaged over 10 grams of tissue.

SAR tests are carried out with the device in standard operating positions, transmitting at its highest certified power level, in all its frequency bands. The maximum recorded SAR values for this device are:

	Maximum SAR value	Frequency bands used when Maximum SAR value was recorded
When used in direct contact with the body	1.77 W/kg over 10g	3-slot GPRS 1800

Your mobile device is also designed to meet the United States Federal Communications Commission (FCC) and Industry Canada SAR (IC) guidelines. FCC ratings for your device and more information on SAR can be found at [transition.fcc.gov/oet/rfsafety/sar.html](http://transition.fcc.gov/oet/rfsafety/sar.html). Information on IC SAR can be found at [www.ic.gc.ca](http://www.ic.gc.ca).

To send data or messages, a good connection to the network is needed. Sending may be delayed until such a connection is available. Follow the separation distance instructions until the sending is finished.



During general use, the SAR values are usually well below the values stated above. This is because, for purposes of system efficiency and to minimise interference on the network, the operating power of your mobile is automatically decreased when full power is not needed for the call. The lower the power output, the lower the SAR value.

Device models may have different versions and more than one value. Component and design changes may occur over time and some changes could affect SAR values. The latest available SAR information for this and other Nokia device models can be found at [www.nokia.com/sar](http://www.nokia.com/sar).

The World Health Organization (WHO) has stated that current scientific information does not indicate the need for any special precautions when using mobile devices. If you are interested in reducing your exposure, they recommend you limit your usage or use a hands-free kit to keep the device away from your head and body. For more information and explanations and discussions on RF exposure, go to the WHO website at [www.who.int/peh-emf/en](http://www.who.int/peh-emf/en).

### **Nokia Care**

For questions regarding your plans, billing or network please contact your operator. For questions regarding your Nokia product and warranty, please visit the support pages for your country at [www.nokia.com/support](http://www.nokia.com/support).

## **Copyrights and other notices**

### **DECLARATION OF CONFORMITY**

**CE 0168**

Hereby, NOKIA CORPORATION declares that this RX-114 product is in compliance with the essential requirements and other relevant provisions of Directive 1999/5/EC. A copy of the Declaration of Conformity can be found at [www.nokia.com/global/declaration/declaration-of-conformity](http://www.nokia.com/global/declaration/declaration-of-conformity).

The availability of products, features, apps and services may vary by region. For more info, contact your Nokia dealer or your service provider. This device may contain commodities, technology or software subject to export laws and regulations from the US and other countries. Diversion contrary to law is prohibited.

THE CONTENTS OF THIS DOCUMENT ARE PROVIDED “AS IS”. EXCEPT AS REQUIRED BY APPLICABLE LAW, NO WARRANTIES OF ANY KIND, EITHER EXPRESS OR IMPLIED, INCLUDING, BUT NOT LIMITED TO, THE IMPLIED WARRANTIES OF MERCHANTABILITY AND FITNESS FOR A PARTICULAR PURPOSE, ARE MADE IN RELATION TO THE ACCURACY, RELIABILITY OR CONTENTS OF THIS DOCUMENT. NOKIA RESERVES THE RIGHT TO REVISE THIS DOCUMENT OR WITHDRAW IT AT ANY TIME WITHOUT PRIOR NOTICE.

TO THE MAXIMUM EXTENT PERMITTED BY APPLICABLE LAW, UNDER NO CIRCUMSTANCES SHALL NOKIA OR ANY OF ITS LICENSORS BE RESPONSIBLE FOR ANY LOSS OF DATA OR INCOME OR ANY SPECIAL, INCIDENTAL, CONSEQUENTIAL OR INDIRECT DAMAGES HOWSOEVER CAUSED.

Reproduction, transfer or distribution of part or all of the contents in this document in any form without the prior written permission of Nokia is prohibited. Nokia operates a policy of continuous development. Nokia reserves the right to make changes and improvements to any of the products described in this document without prior notice.

Nokia does not provide a warranty for or take any responsibility for the functionality, content, or end-user support of third-party apps provided with your device. By using an app, you acknowledge that the app is provided as is. Nokia does not make any representations, provide a warranty, or take any responsibility for the functionality, content, or end-user support of third-party apps provided with your device.

The availability of particular products, apps, services and features may vary by region. Please check with your service provider or local Nokia dealer for further details and availability of language options.

The social networking services are third-party services and not provided by Nokia. Check the privacy settings of the social networking service you are using as you may share info with a large group of people. The terms of use of the social networking service apply to sharing info on that service. Familiarize yourself with the terms of use and the privacy practices of that service.

### **FCC/INDUSTRY CANADA/MEXICO NOTICE**

This device complies with part 15 of the FCC rules and Industry Canada license-exempt RSS standard(s). Operation is subject to the following two conditions: (1) This device may not cause harmful interference, and (2) this device must accept any interference received, including interference that may cause undesired operation. Any changes or modifications not expressly approved by Nokia could void the user's authority to operate this equipment.

Note: This equipment has been tested and found to comply with the limits for a Class B digital device, pursuant to part 15 of the FCC Rules. These limits are designed to provide reasonable protection against harmful interference in a residential installation. This equipment generates, uses and can radiate radio frequency energy and, if not installed and used in accordance with the instructions, may cause harmful interference to radio communications. However, there is no guarantee that interference will not occur in a particular installation. If this equipment does cause harmful interference to radio or television reception, which can be determined by turning the equipment off and

on, the user is encouraged to try to correct the interference by one or more of the following measures:

- Reorient or relocate the receiving antenna.
- Increase the separation between the equipment and receiver.
- Connect the equipment into an outlet on a circuit different from that to which the receiver is connected.
- Consult the dealer or an experienced radio/TV technician for help.

TM & © 2013 Nokia. All rights reserved. Third party products/names may be TMs of their respective owners.

© 2013 Microsoft Corporation. All rights reserved. Microsoft, Windows and the Windows logo are trademarks of the Microsoft group of companies.

The Bluetooth word mark and logos are owned by the Bluetooth SIG, Inc. and any use of such marks by Nokia is under license.

This product is licensed under the MPEG-4 Visual Patent Portfolio License (i) for personal and noncommercial use in connection with information which has been encoded in compliance with the MPEG-4 Visual Standard by a consumer engaged in a personal and noncommercial activity and (ii) for use in connection with MPEG-4 video provided by a licensed video provider. No license is granted or shall be implied for any other use. Additional information, including that related to promotional, internal, and commercial uses, may be obtained from MPEG LA, LLC. See [www.mpegla.com](http://www.mpegla.com).